

# TACH CONVERSION KIT COMPONENT CHECKLIST

\*\*\*IMPORTANT NOTICE\*\*\*

This tachometer unit must be used with V8 applications only!

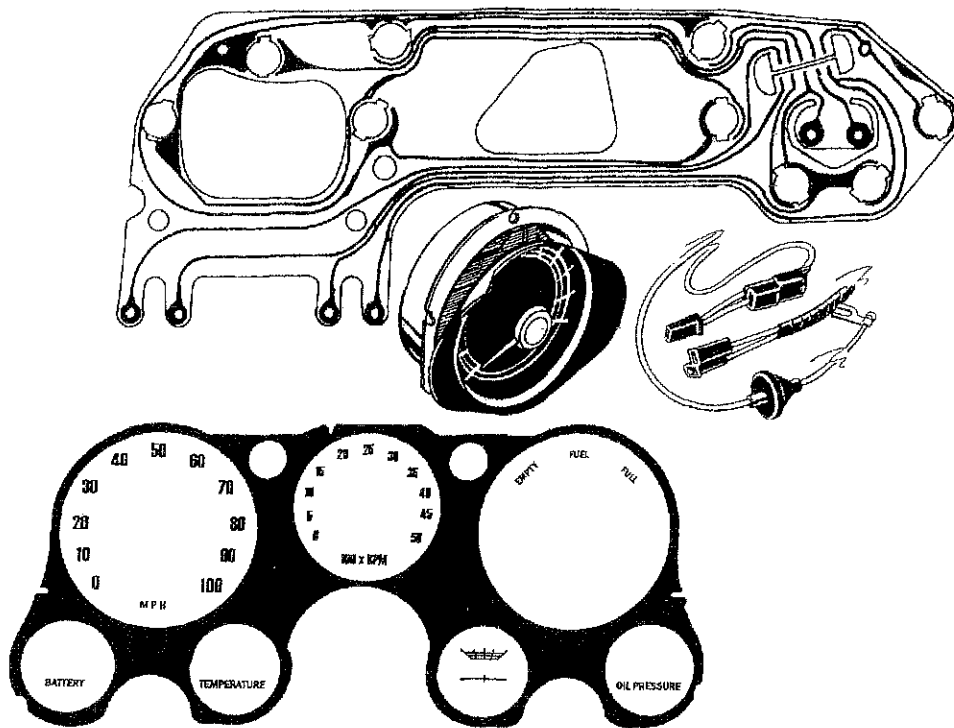

## Tach Conversion Components

- 1) Tachometer Gauge (V8)
- 3) Tachometer Gauge Mount Screws
- 1) Printed Circuit, w/tach
- 1) Tachometer Wire Harness
- 1) Instrument Lens, w/tach
- 1) Front Gauge Housing, w/tach
- 1) Rear Gauge Housin, w/tach

INSTRUCTION SHEET  
TACHOMETER CONVERSION KIT  
1967-72 CHEVROLET / GMC TRUCK

PART NO.

**92964826**

SHEET

1 OF 3

# TACHOMETER INSTALLATION

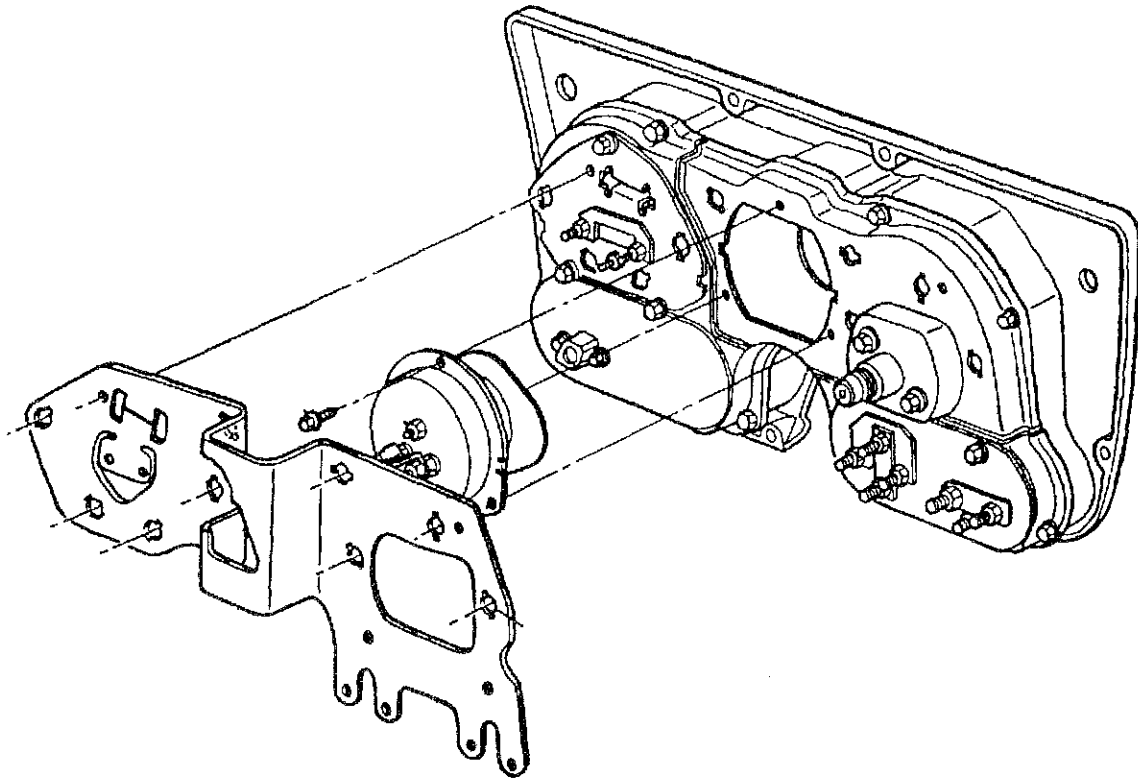

1. Disconnect the battery.
2. Remove instrument cluster from dash.
3. Place cluster face down on work surface.
4. Remove all light bulb sockets and ground screws.
5. Remove printed circuit.
6. Remove all gauges from back housing.
7. Remove the (8) screws which attach the instrument bezel to back housing.
8. Install new gauges onto new back plate.
9. Install your new tachometer into new back plate. (The two tabs on tachometer can be used to better position and hold the gauge onto housing.)
10. Remove old front housing plate and lens.
11. Install new lens and front housing plate. (New lens may be tight when inserting into bezel, you can adjust by filing the edges of the lens slightly.)
12. Install new back plate with gauges.
13. Install new printed circuit.
14. Make sure all gauge and ground screws are secured tightly.

INSTRUCTION SHEET  
TACHOMETER CONVERSION KIT  
1967-72 CHEVROLET / GMC TRUCK

PART NO.

**92974826**

SHEET

2 OF 3

# WIRE HARNESS INSTALLATION

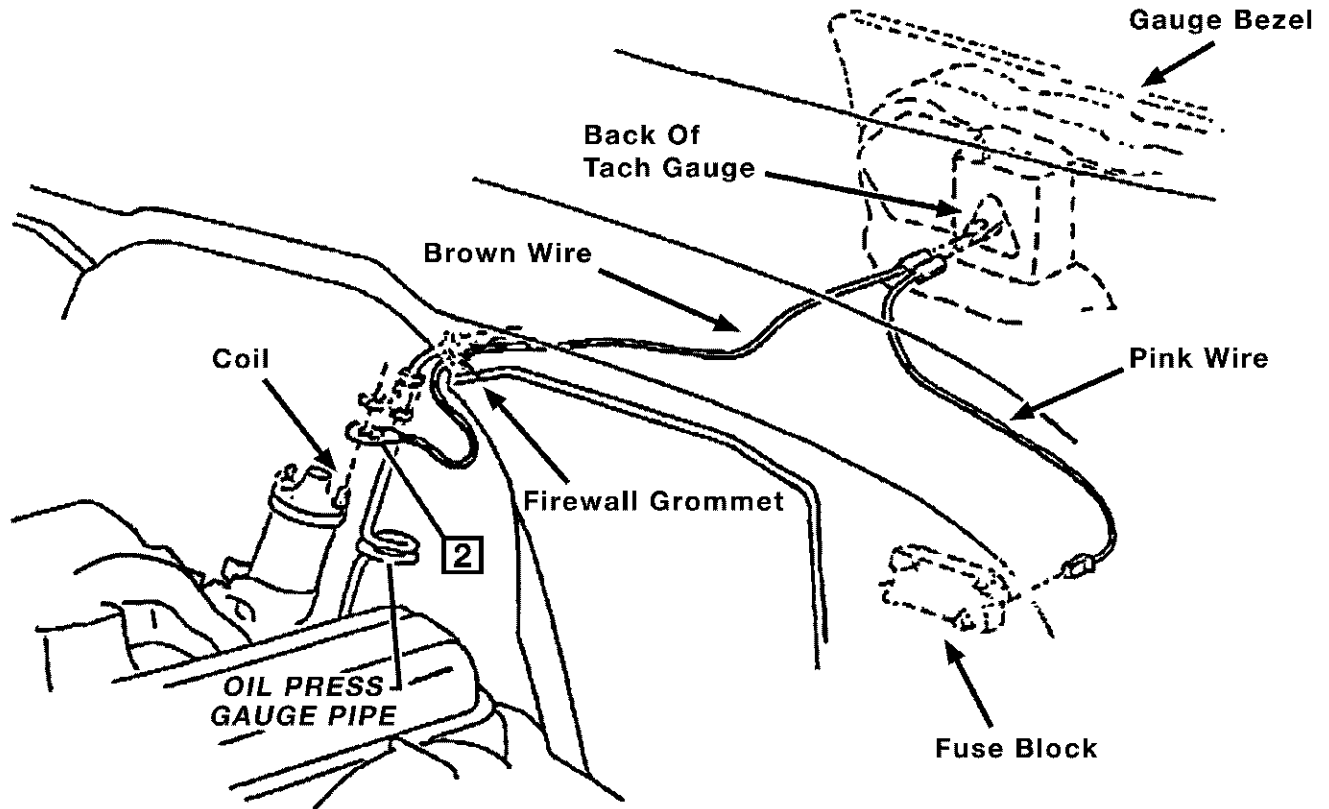

1. Run tachometer wire harness from the outside of the firewall to the inside of the cab until firewall grommet stops the progression.
  2. Insert firewall grommet into hole.  
(If hole does not exist, it is necessary to drill a 3/4" diameter hole.)
  3. Install "V" shaped plug onto the back of the tachometer gauge. It may be necessary to loosen the male terminal nuts slightly to position it in the correct location to accept the plug.
- \* Pink Wire is located on the left hand side of the "V" plug.  
After connection on male terminal, the reverse side must be plugged into the fuse block receptacle marked "IGN UNFUSED."
  - \* Brown Wire is located on the right hand side of the "V" plug.  
After connection onto male terminal, the reverse side must be bolted onto the negative post of coil.

INSTRUCTION SHEET  
TACHOMETER CONVERSION KIT  
1967-72 CHEVROLET / GMC TRUCK

PART NO.

**92974826**

SHEET

3 OF 3