

## 5-WAY SPARE FUSE HOLDER WITH 30MM MOUNTING RAILS

- THIS 5-WAY SPARE FUSE HOLDER ALLOWS SPARE FUSES TO BE STOWED AND ATTACHED DIRECTLY TO AN ATO SERIES FUSE BLOCK WITH AVAILABLE 30MM MOUNTING RAILS.
- THE CUSTOMER MUST DETERMINE IF THERE IS SUFFICIENT CLEARANCE TO MOUNT THIS FUSE HOLDER TO THE FUSE BLOCK. SEE PAGE 2.
- FUSES ARE NOT PROVIDED.

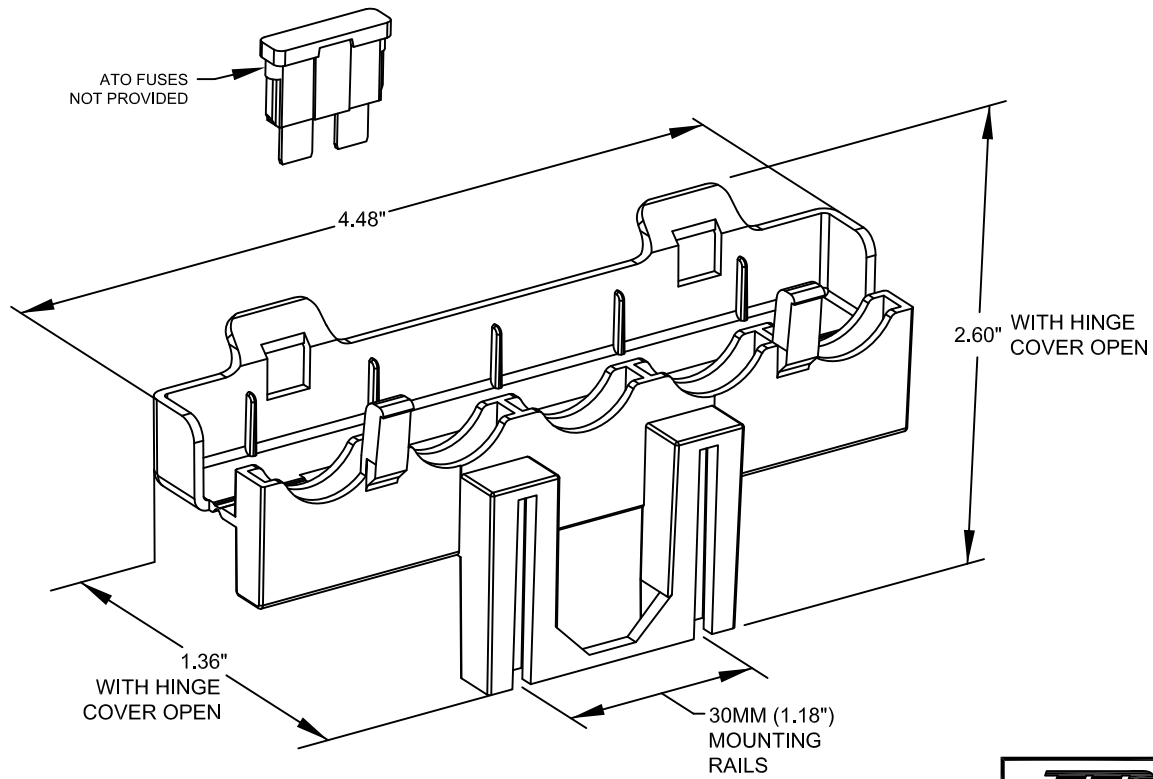

TITLE

INSTRUCTION SHEET  
5-WAY SPARE FUSE HOLDER  
WITH 30MM MOUNTING RAILS

DWG NO.

**92974682**

SHEET NO.

1 OF 3

# VERIFY FUSE HOLDER CLEARANCE

BEFORE PROCEEDING, VERIFY FUSE BLOCK HAS ENOUGH CLEARANCE IN THE VEHICLE TO ATTACH THE 5-WAY FUSE HOLDER. SEE FIGURES 1 & 2.

NOTE: FUSE BLOCK SHOWN IS FOR REFERENCE ONLY. YOUR FUSE BLOCK MAY LOOK DIFFERENT BUT CLEARANCE WILL STILL NEED TO BE VERIFIED. SEE PAGE 3.

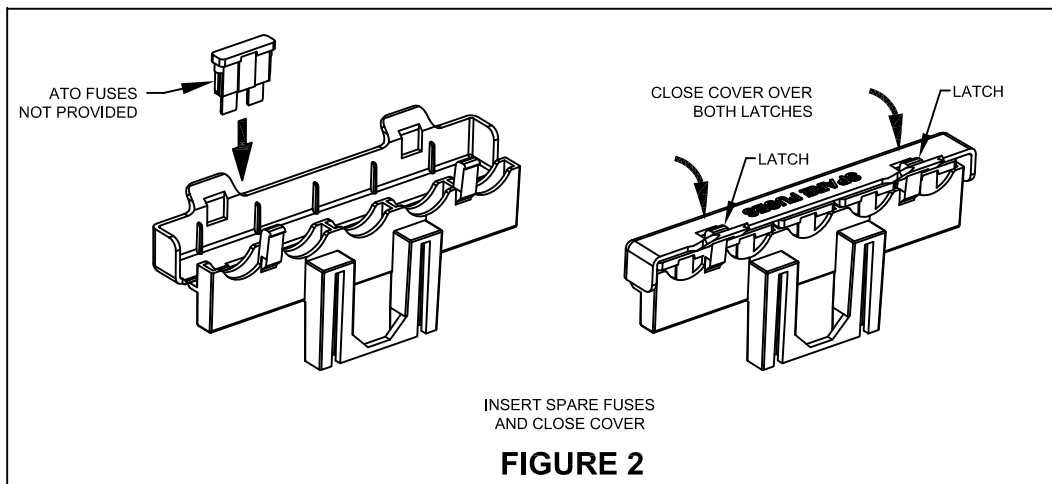
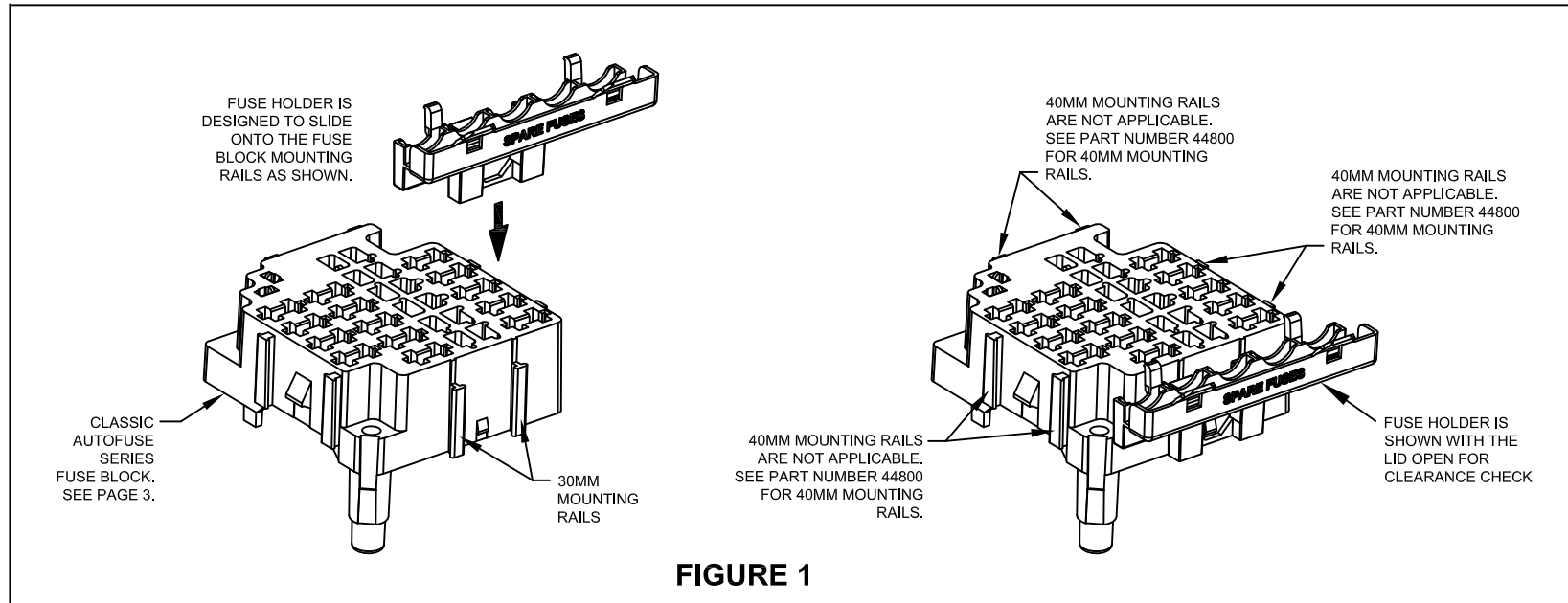

**NOTE:**  
CUSTOMER MUST DETERMINE IF THERE IS SUFFICIENT SPACE TO ATTACH THE FUSE HOLDER TO THE ATO FUSE BLOCK AFTER DASH HARNESS HAS BEEN INSTALLED IN VEHICLE.

**M&H ELECTRIC FABRICATORS, INC.**  
AUTOMOTIVE WIRING SYSTEMS  
(562) 926-9552 www.wiringharness.com

TITLE  
INSTRUCTION SHEET  
5-WAY SPARE FUSE HOLDER  
WITH 30MM MOUNTING RAILS

DWG NO. **92974682**

SHEET NO.  
2 OF 3

# 5-WAY JUNCTION BLOCK ATTACHMENT OPTIONS TO CLASSIC AUTOFUSE SERIES DASH HARNESSSES

(SEE CATALOG APPLICATIONS FOR SPECIFIC DASH HARNESS PART NUMBERS USING THESE FUSE BLOCKS)

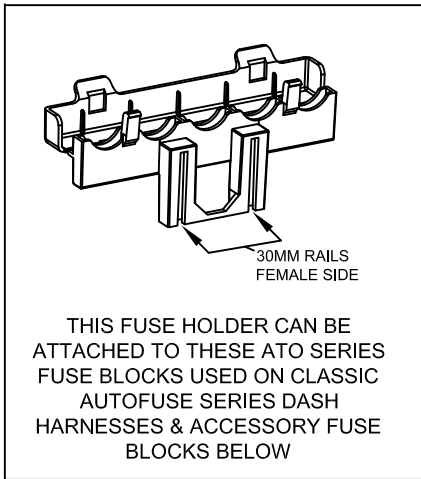

**THIS ATO SERIES FUSE BLOCK IS USED ON THE FOLLOWING CAR LINES:**

<p>40MM MALE MOUNTING RAILS ARE NOT APPLICABLE. SEE PART NUMBER 44800 FOR 40MM FUSE HOLDER.</p> <p>30MM MALE MOUNTING RAILS</p>	<p><u>1964-67 GM "A" BODY:</u></p> <ul style="list-style-type: none"> <li>• CHEVELLE / EL CAMINO</li> <li>• SKYLARK / GS</li> <li>• GTO / LEMANS</li> <li>• CUTLASS / 442</li> </ul>
	<p><u>1963-67 GM "B" BODY:</u></p> <ul style="list-style-type: none"> <li>• IMPALA</li> <li>• CAPRICE</li> <li>• BISCAYNE</li> <li>• BEL AIR</li> <li>• AND OTHER CHEVY PASSENGER MODELS</li> </ul>
	<p><u>1967 GM "F" BODY:</u></p> <ul style="list-style-type: none"> <li>• CAMARO</li> <li>• FIREBIRD</li> </ul>
	<p><u>1967-69 "Z" BODY:</u></p> <ul style="list-style-type: none"> <li>• CORVAIR</li> </ul>

**THIS ATO SERIES FUSE BLOCK IS USED ON THE FOLLOWING CAR LINES:**

<p>40MM MALE MOUNTING RAILS ARE NOT APPLICABLE. SEE PART NUMBER 44800 FOR 40MM FUSE HOLDER.</p> <p>40MM MALE MOUNTING RAILS NOT APPLICABLE</p> <p>30MM MALE MOUNTING RAILS</p>	<p><u>1968-77 GM "A" BODY:</u></p> <ul style="list-style-type: none"> <li>• CHEVELLE / EL CAMINO</li> <li>• MONTE CARLO</li> <li>• SKYLARK / GS</li> <li>• GTO / LEMANS</li> <li>• CUTLASS / 442</li> </ul>
	<p><u>1968-71 GM "B" BODY:</u></p> <ul style="list-style-type: none"> <li>• IMPALA</li> <li>• CAPRICE</li> <li>• BISCAYNE</li> <li>• BEL AIR</li> <li>• AND OTHER CHEVY PASSENGER MODELS</li> </ul>
	<p><u>1968-79 GM "F" BODY:</u></p> <ul style="list-style-type: none"> <li>• CAMARO</li> <li>• FIREBIRD</li> <li>• 68 &amp; 69 ALREADY COMPLETE</li> </ul>
	<p><u>1968-74 GM "X" BODY:</u></p> <ul style="list-style-type: none"> <li>• CHEVY II / NOVA</li> </ul>
	<p><u>1968-78 GM "Y" BODY:</u></p> <ul style="list-style-type: none"> <li>• CORVETTE</li> </ul>

30MM MALE MOUNTING RAILS

PART # 44302  
4-WAY ATO ACCESSORY KIT

**THIS ATO SERIES FUSE BLOCK IS USED ON THE FOLLOWING CAR LINES:**

<p>40MM MALE MOUNTING RAILS ARE NOT APPLICABLE. SEE PART NUMBER 44800 FOR 40MM FUSE HOLDER.</p> <p>30MM MALE MOUNTING RAILS</p>	<p><u>1958-62 GM "B" BODY:</u></p> <ul style="list-style-type: none"> <li>• IMPALA</li> <li>• BEL AIR</li> <li>• BISCAYNE</li> <li>• CAPRICE</li> </ul>
	<p><u>1962-67 GM "X" BODY:</u></p> <ul style="list-style-type: none"> <li>• CHEVY II / NOVA</li> </ul>
	<p><u>1958-67 GM "Y" BODY:</u></p> <ul style="list-style-type: none"> <li>• CORVETTE</li> </ul>

**NOTE:**  
CUSTOMER MUST DETERMINE IF THERE IS SUFFICIENT SPACE TO ATTACH THE FUSE HOLDER TO THE ATO FUSE BLOCK AFTER DASH HARNESS HAS BEEN INSTALLED IN VEHICLE.

30MM MALE MOUNTING RAILS

PART # 44301  
4-WAY ATO ACCESSORY KIT WITH SIDE MOUNTS

**M&H ELECTRIC FABRICATORS, INC.**  
AUTOMOTIVE WIRING SYSTEMS  
(562) 926-9552 www.wiringharness.com

TITLE  
**INSTRUCTION SHEET  
5-WAY SPARE FUSE HOLDER  
WITH 30MM MOUNTING RAILS**

DWG NO. **92974682** SHEET NO. 3 OF 3