

4-WAY ATO ACCESSORY FUSE BLOCK WITH SIDE MOUNTS & TERMINAL KIT

- THIS KIT IS USED TO PROTECT UP TO 4 FUSED ACCESSORIES TO THE 4-WAY ACCESSORY FUSE BLOCK.
- THIS KIT CAN BE 4 SEPARATE FUSES OR CAN BE BUSSED AS NEEDED WITH COMMON FEEDS UP TO 4-WAY.
- THIS KIT CAN BE USED WITH ATO SERIES FUSING OR CIRCUIT BREAKERS AS LARGE AS 30 AMP PER CAVITY.
- THIS KIT IS DESIGNED TO BE USED AS A STAND-ALONE APPLICATION FOR IN-LINE USE. IT CAN ALSO BE ATTACHED TO ALL CLASSIC AUTOFUSE SERIES FUSE BLOCKS WITH 30MM MOUNTING RAILS. SEE SPECIFIC APPLICATIONS FOR FOR RAIL LOCATIONS. SEE PAGE 10.
- THIS KIT ALLOWS MULTIPLE KITS TO BE ASSEMBLED TOGETHER AND INTERLOCKED WITH THE 30MM MOUNTING RAILS. IT CAN ALSO BE ASSEMBLE AND STACKED WITH KIT 44302. SEE PAGE 10.

CONTENTS

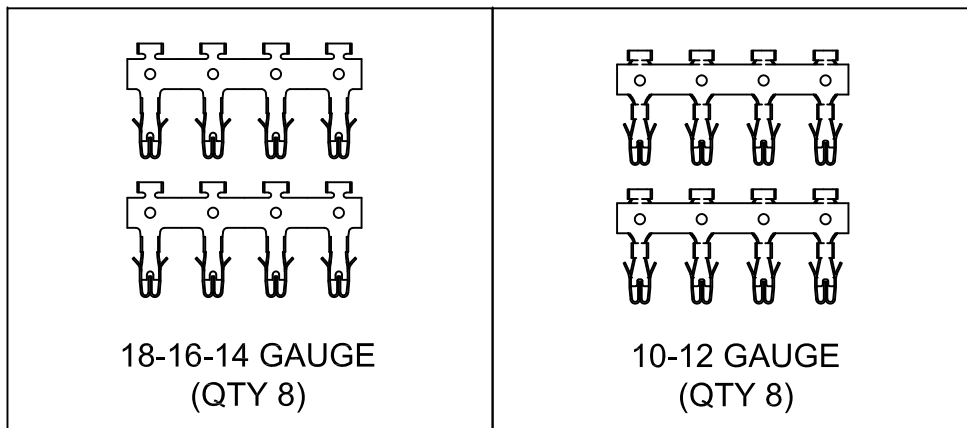
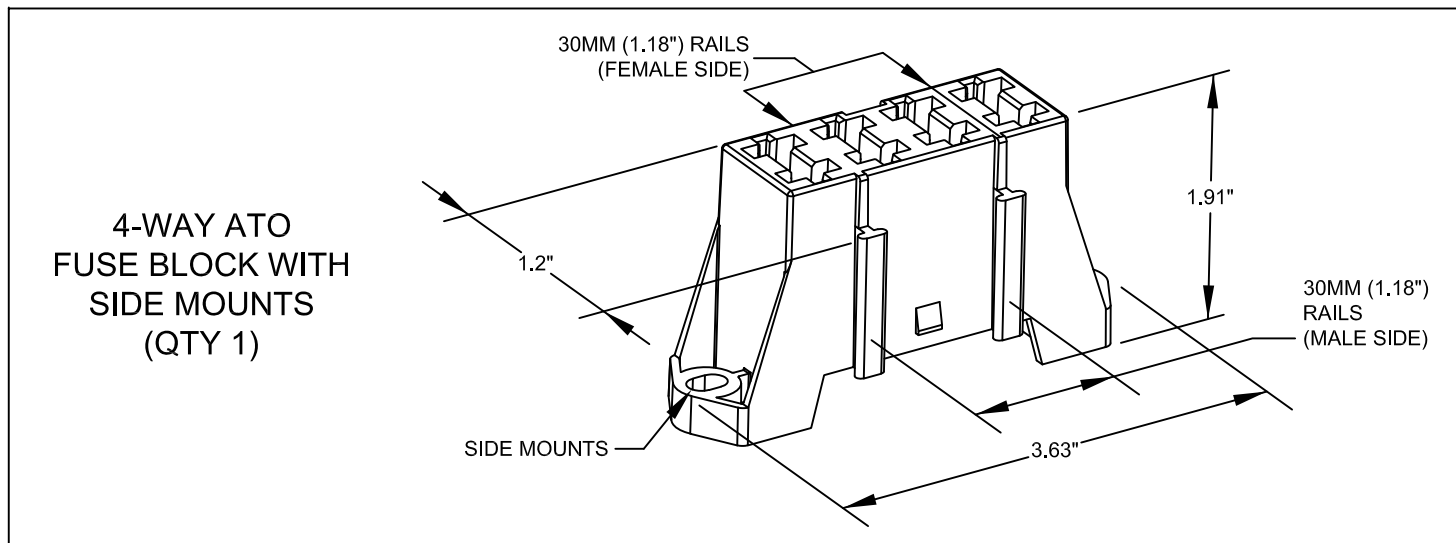

TITLE	INSTRUCTION SHEET 4-WAY ATO ACCESSORY FUSE BLOCK KIT WITH SIDE MOUNTS AND 30MM MOUNTING RAILS	
DWG NO.	92974214	SHEET NO. 1 OF 10

4-WAY ATO ACCESSORY FUSE BLOCK WITH SIDE MOUNTS & TERMINAL KIT

READ ALL INSTRUCTIONS CAREFULLY BEFORE PROCEEDING.

THE CUSTOMER MUST DETERMINE IF THERE IS SUFFICIENT CLEARANCE TO ATTACH THIS 4-WAY ATO FUSE BLOCK FOR USE IN A STAND-ALONE IN-LINE APPLICATION. OR VERIFY SPACE REQUIREMENTS TO ATTACH IT TO A CLASSIC AUTOFUSE SERIES FUSE BLOCK WITH 30MM RAILS. SEE PAGE 3. THIS ACCESSORY FUSE BLOCK MAY NOT FIT IN SOME VEHICLE APPLICATIONS BECAUSE OF STRUCTURAL DEVICES SUCH AS AN EMERGENCY BRAKE PEDAL BRACKET, ETC. SEE THE CLASSIC AUTOFUSE SERIES DASH HARNESS INSTRUCTIONS FOR MORE INFORMATION AND LINE DRAWINGS SHOWING MOUNTING RAIL LOCATIONS AND POSITIONS ON THE NEW CLASSIC AUTOFUSE SERIES FUSE BLOCKS FOR THE SPECIFIC APPLICATIONS.

THE CUSTOMER IS RESPONSIBLE FOR DETERMINING THE AMPERAGE LOAD NEEDED TO ENSURE THE APPROPRIATE BUS BAR AND/OR INDIVIDUAL TERMINAL IS SELECTED FOR HANDLING THE CONNECTED DEVICE AMPERAGE LOADS. SEE PAGE 4 FOR GUIDELINES.

THESE INSTRUCTIONS ARE ARRANGED AS FOLLOWS:

PAGE 3: VERIFY FUSE BLOCK MOUNTING CLEARANCE OR DETERMINE MOUNTING DETAILS FOR STAND-ALONE APPLICATION.

PAGE 4: GUIDELINES FOR DETERMINING LOAD REQUIREMENTS FOR FUSE BLOCK BUS BAR & SINGLE TERMINALS.

PAGE 5: BUS BAR PREPARATION & SINGLE TERMINAL PREPARATION.

PAGE 6: FUSE BLOCK ASSEMBLY.

PAGE 7: BUS BAR REMOVAL INSTRUCTIONS.

PAGE 8: FUSE BLOCK APPLICATION EXAMPLES.

PAGE 9: TYPICAL FUSE BLOCK SCHEMATIC EXAMPLES.

PAGE 10: OPTIONAL 4-WAY ATO FUSE BLOCK ATTACHMENT OPTIONS TO CLASSIC AUTOFUSE RESTORATION SERIES DASH HARNESSES WITH ATO FUSE BLOCKS.

 AUTOMOTIVE WIRING SYSTEMS (562) 926-9552 www.wiringharness.com	
TITLE INSTRUCTION SHEET 4-WAY ATO ACCESSORY FUSE BLOCK KIT WITH SIDE MOUNTS AND 30MM MOUNTING RAILS	
DWG NO. 92974214	SHEET NO. 2 OF 10

VERIFY 4-WAY FUSE BLOCK CLEARANCE

BEFORE PROCEEDING, VERIFY CLASSIC AUTOFUSE SERIES FUSE BLOCK HAS ENOUGH CLEARANCE IN THE VEHICLE TO ATTACH THE 4-WAY FUSE BLOCK. SEE FIGURE 1 & 2.

IF 4-WAY FUSE BLOCK WILL BE USED IN A STAND-ALONE APPLICATION, VERIFY THERE IS ENOUGH CLEARANCE IN YOUR DESIRED LOCATION. SEE FIGURE 3. NOTE THAT 4-WAY FUSE BLOCKS CAN BE ASSEMBLED TOGETHER IF DESIRED AND THERE IS ENOUGH SPACE. TYPICAL LOCATION FOR MOUNTING IS NEAR FUSE BLOCK. HOWEVER, IT CAN BE LOCATED IN THE ENGINE COMPARTMENT OR PASSENGER COMPARTMENT.

NOTE: THE CLASSIC AUTOFUSE SERIES FUSE BLOCK SHOWN IS FOR REFERENCE ONLY. YOUR FUSE BLOCK MAY LOOK DIFFERENT BUT CLEARANCE WILL STILL NEED TO BE VERIFIED.

IF THERE IS ENOUGH CLEARANCE TO MOUNT THE 4-WAY FUSE BLOCK ON THE AVAILABLE 30MM RAILS, OR IN A STAND-ALONE APPLICATION, THEN PROCEED TO PAGE 4 OF THESE INSTRUCTIONS.

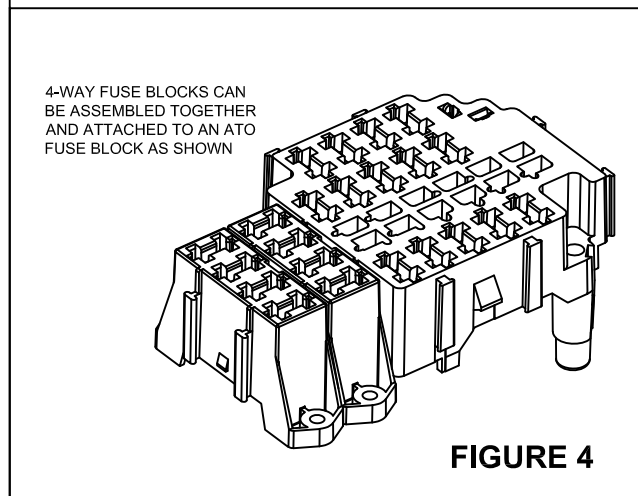
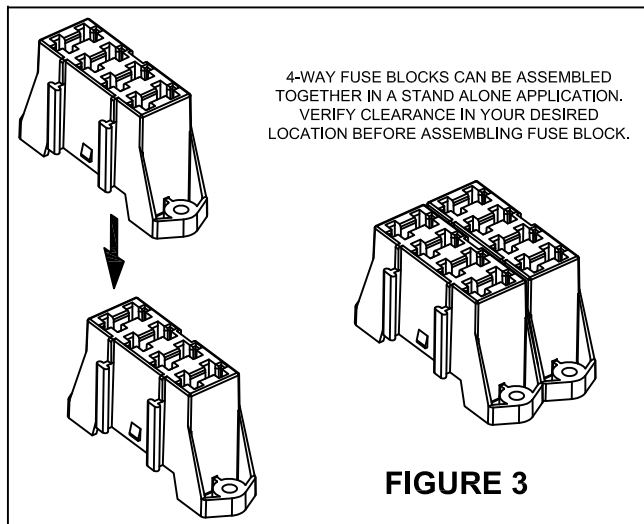
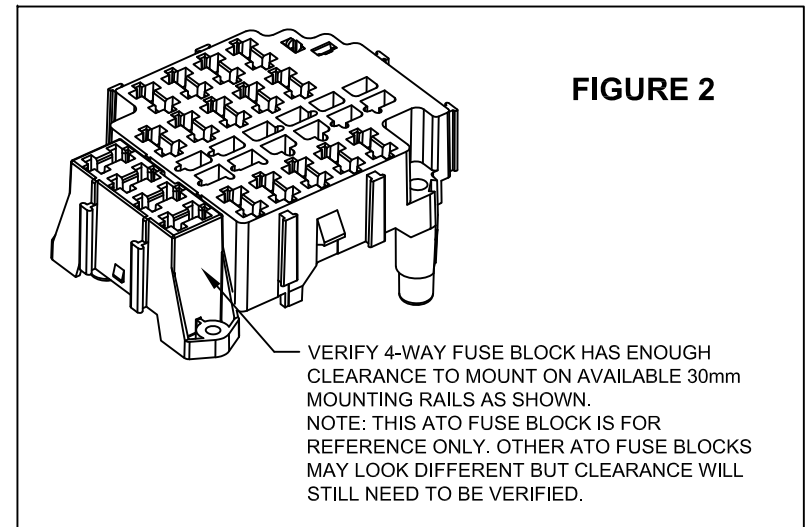
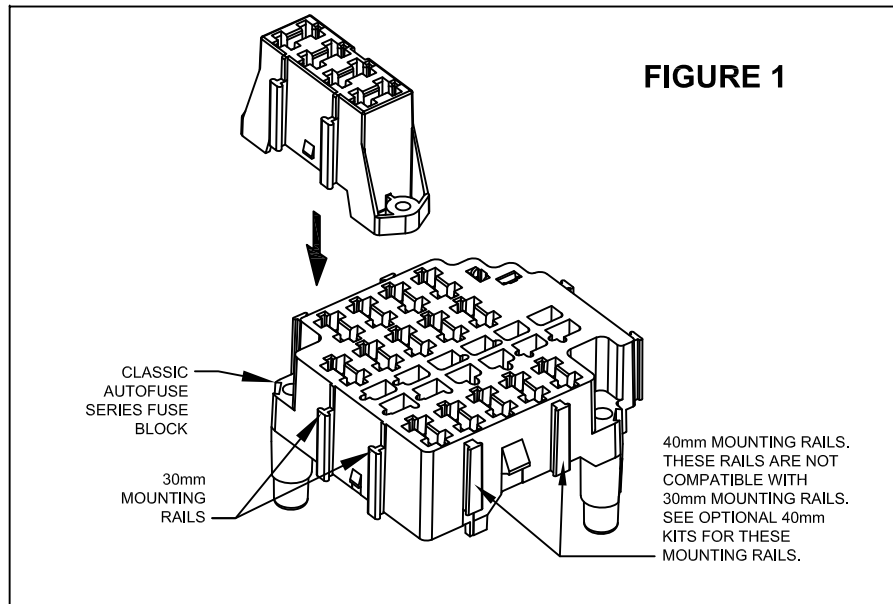

TITLE	
INSTRUCTION SHEET 4-WAY ATO ACCESSORY FUSE BLOCK KIT WITH SIDE MOUNTS AND 30MM MOUNTING RAILS	
DWG NO.	SHEET NO.
92974214	3 OF 10

GUIDELINES FOR DETERMINING BUS BAR AMPERAGE AND CONFIGURATION

THE CUSTOMER IS RESPONSIBLE FOR ENSURING PROPER FUSING AND BUS BAR SELECTION OF EACH CIRCUIT & AMPERAGE LOAD DESIGN WHEN USING THIS KIT. SEE FIGURES 5 & 6 FOR BUS BAR SELECTION GUIDELINES.

THIS KIT ALLOWS THE BUS BAR TO BE USED TO BUS 2 TO 4 FUSE CAVITIES WITH THE SAME FEED. OR BUS BAR CAN BE TRIMMED TO INDIVIDUAL TERMINALS IF DESIRED. OR ANY COMBINATION DESIRED. SEE FIGURE 7. USE SUFFICIENT DIAGONAL CUTTERS OR EQUIVALENT TO CUT THE BUS BAR TO DESIRED SIZE AS STRAIGHT AND CLEAN AS POSSIBLE. SEE FIGURE 7.

CAUTION: WHEN TRIMMING BUS BAR TO DESIRED QUANTITY, BARE SIDES MUST BE TRIMMED TO CORRECT DIMENSION SHOWN IN FIGURE 9 OR BUS BAR MAY NOT FIT CORRECTLY IN FUSE BLOCK AND IT MAY ALSO CONTACT TERMINALS IN ADJACENT CAVITIES IF THEY ARE PRESENT. BARE SIDES MUST BE TRIMMED TO THE CORRECT DIMENSION FOR ALL BUS BAR CONFIGURATIONS AS WELL AS SINGLE TERMINAL APPLICATIONS.

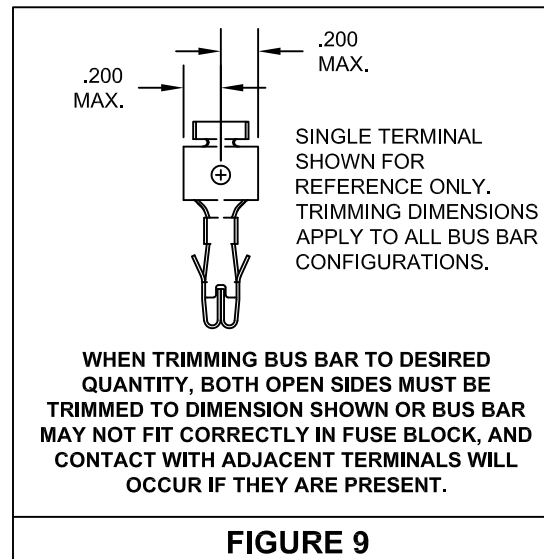
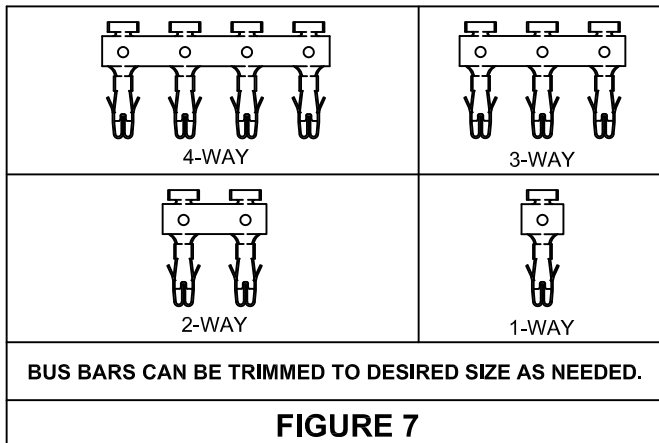
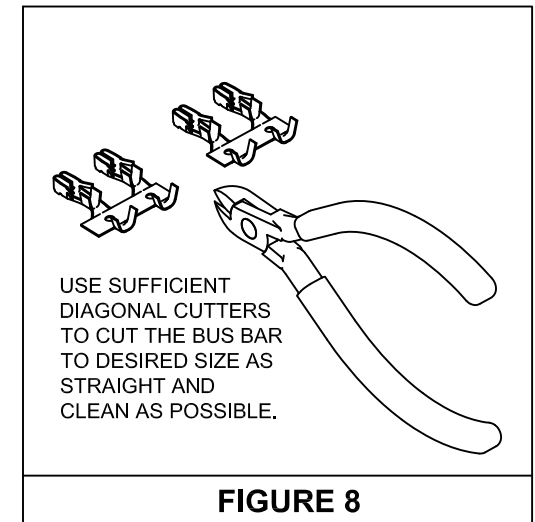
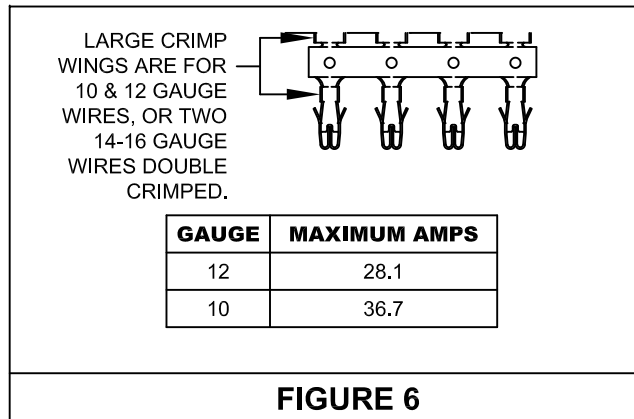
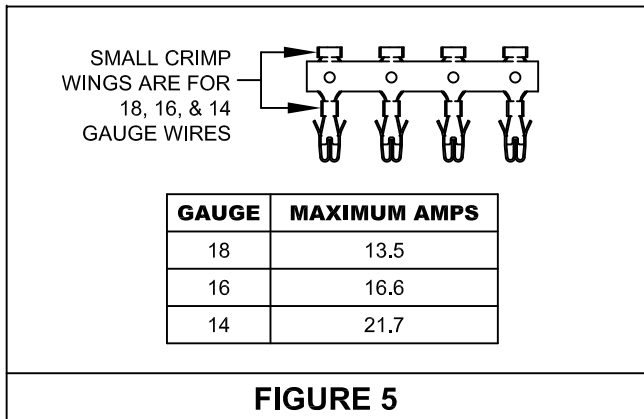

M&H ELECTRIC FABRICATORS, INC.
AUTOMOTIVE WIRING SYSTEMS
(562) 926-9552 www.wiringharness.com

TITLE
INSTRUCTION SHEET
4-WAY ATO ACCESSORY FUSE
BLOCK KIT WITH SIDE MOUNTS AND
30MM MOUNTING RAILS

DWG NO. **92974214** SHEET NO. 4 OF 10

TERMINATING AND PREPARING THE BUS BAR

CRIMP WIRE TO BUS BAR AS SHOWN IN STEPS 1-4.

NOTE: A 4-WAY BUS BAR IS SHOWN FOR REFERENCE ONLY. THESE INSTRUCTIONS APPLY TO ALL BUS BAR TERMINAL CONFIGURATIONS AS WELL AS A SINGLE BUS BAR TERMINAL.

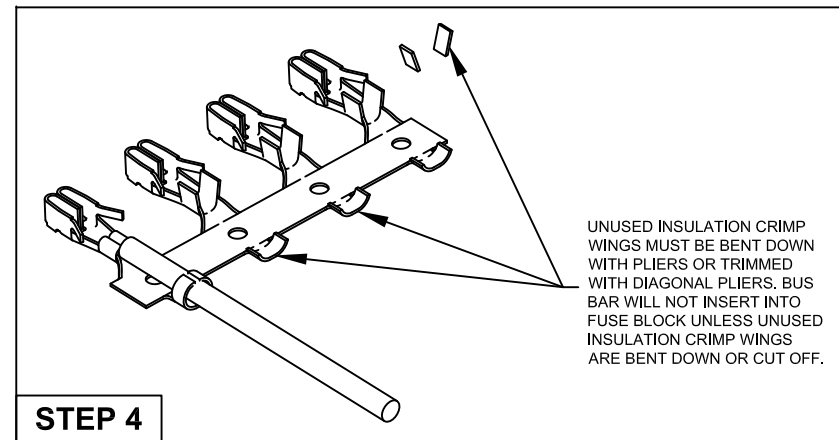
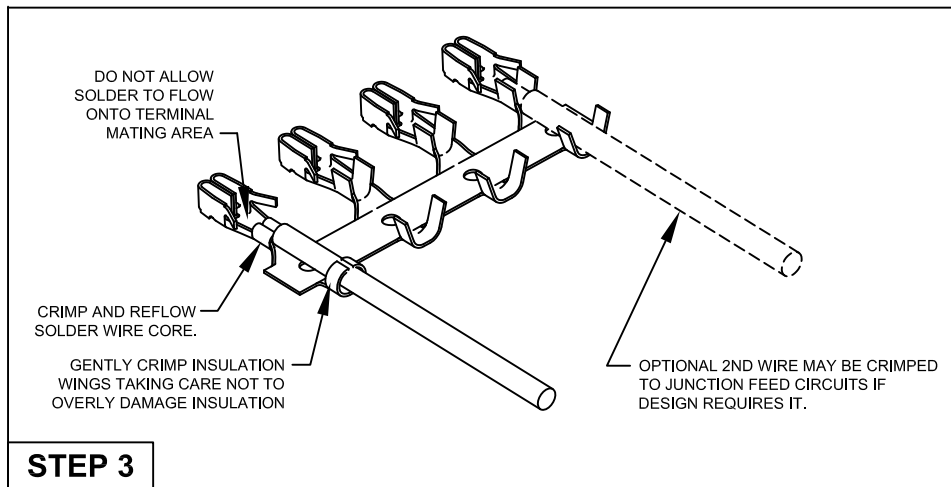
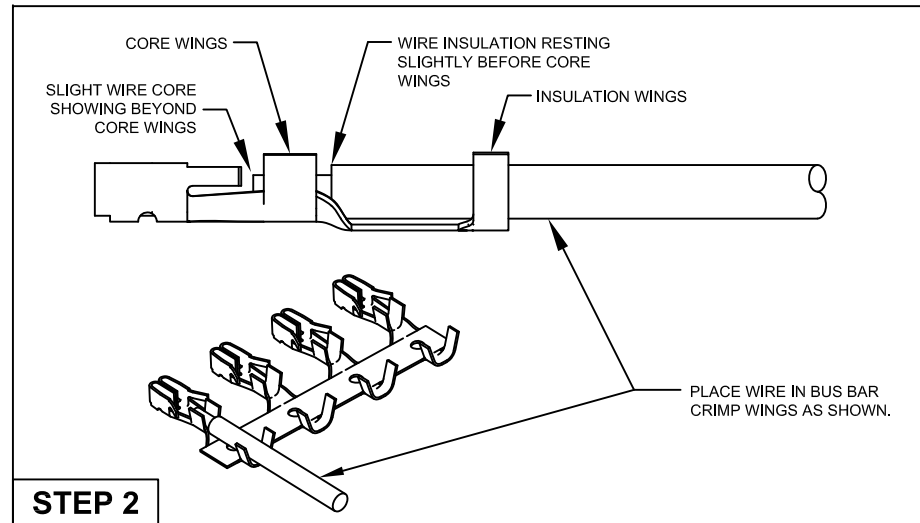
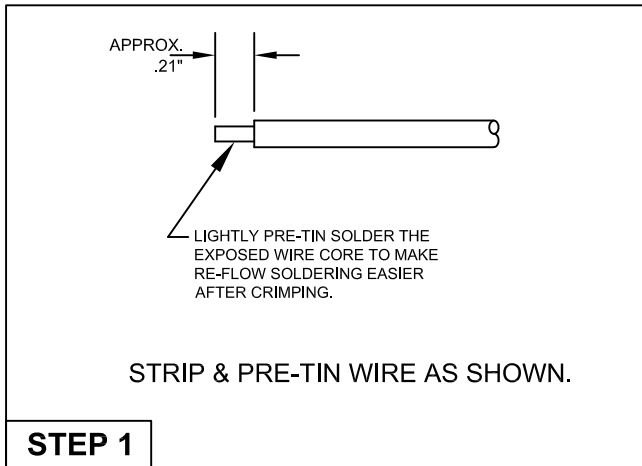

NOTE : COMMERCIAL CRIMPERS FOR "B" CRIMPING ARE VERY COMMON AND SHOULD BE USED ON SINGLE TERMINALS. HOWEVER, THEY DO NOT FULLY MEET FACTORY CRIMP SPECIFICATIONS SO SOLDERING IS RECOMMENDED.

M&H ELECTRIC FABRICATORS, INC.
 AUTOMOTIVE WIRING SYSTEMS
 (562) 926-9552 www.wiringharness.com

TITLE
 INSTRUCTION SHEET
 4-WAY ATO ACCESSORY FUSE
 BLOCK KIT WITH SIDE MOUNTS AND
 30MM MOUNTING RAILS

DWG NO. **92974214** SHEET NO. 5 OF 10

FUSE BLOCK ASSEMBLY

UNUSED CRIMP WINGS
MUST BE BENT DOWN OR
TRIMMED. SEE PAGE 7.

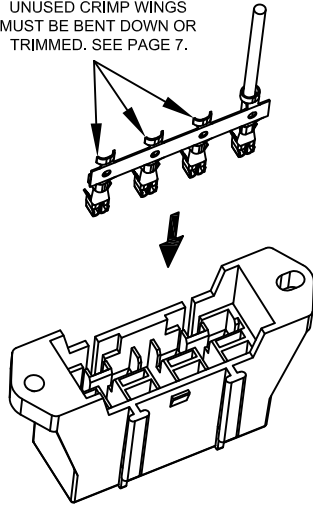

INSERT BUS BAR INTO
DESIRED CAVITIES

"CLICK"

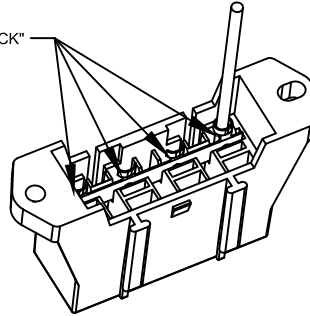

PUSH BUS BAR ALL THE WAY IN
UNTIL EACH TERMINAL "CLICKS" IN
THE LOCKED POSITION

INSERT BUS BAR

INSERT SINGLE
TERMINALS AS
DESIRED.

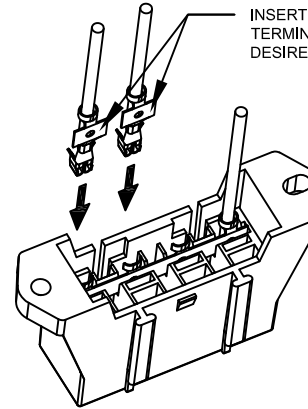

"CLICK"

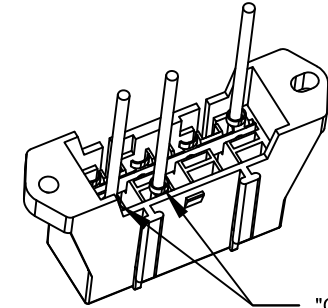

INSERT SINGLE TERMINALS ALL THE
WAY IN UNTIL EACH TERMINAL
"CLICKS" IN THE LOCKED POSITION

INSERT SINGLE TERMINALS

VERIFY ALL TERMINALS ARE
FULLY SEATED FOR PROPER
FUSE ENGAGEMENT.

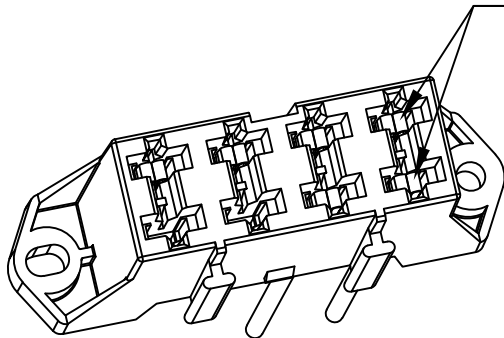

VERIFY TERMINALS ARE FULL SEATED

M&H ELECTRIC
FABRICATORS, INC.
AUTOMOTIVE WIRING SYSTEMS
(562) 926-9552 www.wiringharness.com

TITLE

INSTRUCTION SHEET
4-WAY ATO ACCESSORY FUSE
BLOCK KIT WITH SIDE MOUNTS AND
30MM MOUNTING RAILS

DWG NO.

92974214

SHEET NO.

6 OF 10

TERMINAL REMOVAL

THIS PAGE SHOWS HOW TO REMOVE THE BUS BAR AND SINGLE TERMINALS FROM FUSE BLOCK.

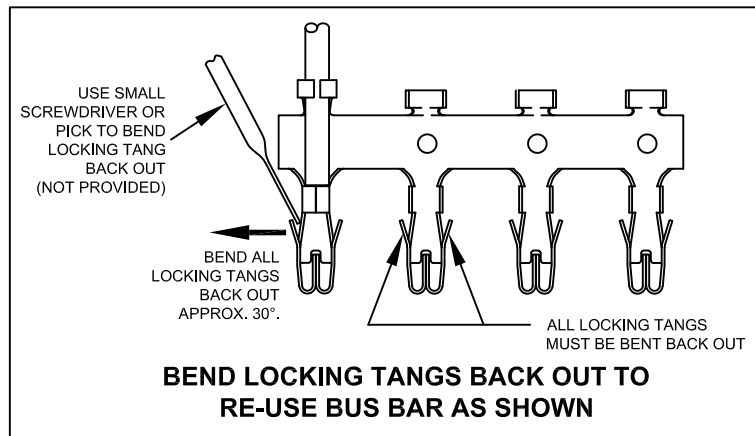
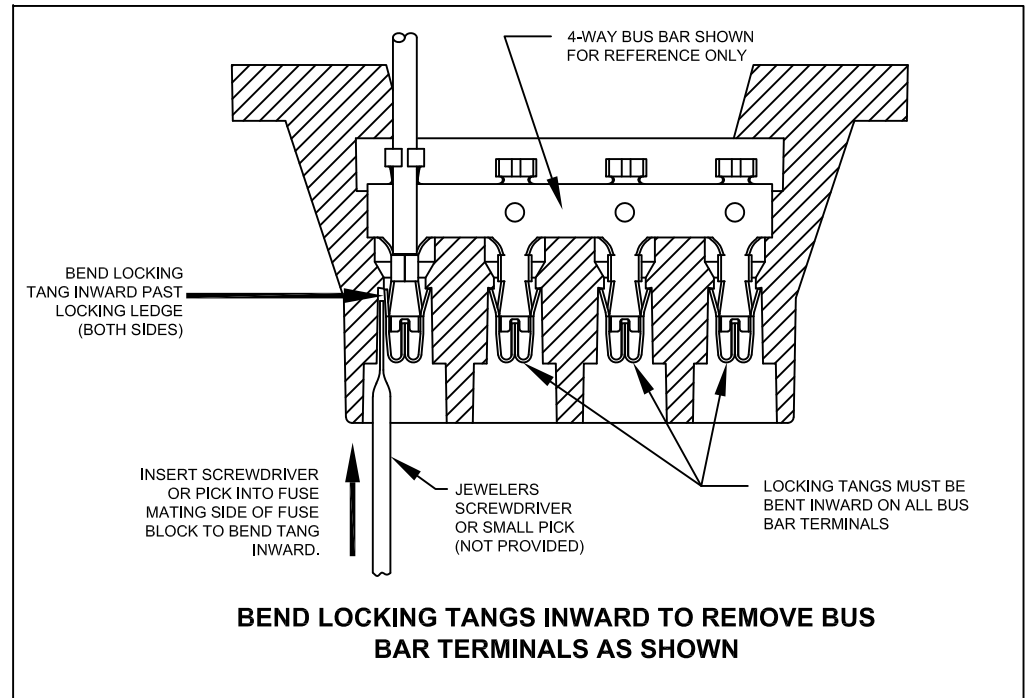
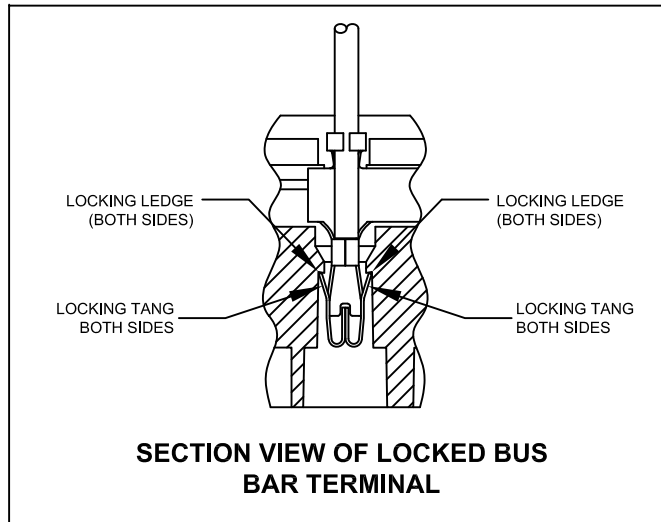

TITLE	INSTRUCTION SHEET 4-WAY ATO ACCESSORY FUSE BLOCK KIT WITH SIDE MOUNTS AND 30MM MOUNTING RAILS	
DWG NO.	92974214	SHEET NO. 7 OF 10

TYPICAL ATO FUSE BLOCK APPLICATION EXAMPLES

THERE ARE MANY USES FOR THIS ATO 4-WAY ATO FUSE BLOCK KIT. IT PROVIDES OPTIONAL FUSED WIRING OF VARIOUS FACTORY ACCESSORIES AND AFTERMARKET DEVICES. HERE ARE SOME OF THE POSSIBLE USES FOR LOW TO HIGH AMPERAGE CAPACITY FUSE BLOCK:

- ELECTRIC FUEL PUMP WITH OR WITHOUT RELAY.
- DUAL ELECTRIC FUEL PUMPS WITH OR WITHOUT RELAYS
- TACHOMETER (AFTER MARKET STEERING COLUMN OR DASH PAD MOUNTED)
- TACHOMETER LAMP (AFTER MARKET STEERING COLUMN OR DASH PAD MOUNTED)
- SHIFT LAMPS (DASH TOP OR STEERING COLUMN MOUNTED)
- SINGLE OR DUAL ELECTRIC FANS WITH RELAY & TEMPERATURE SENDER GROUND.
- ELECTRICAL GAUGES MOUNTED BELOW DASH (OIL PRESSURE, TEMPERATURE, VOLTAGE, ETC.)
- STEREO EQUALIZER
- STEREO AMPLIFIER WITH RELAY
- FRONT FOG OR DRIVING LAMPS WITH OR WITHOUT RELAY
- HIGH INTENSITY LAMPS WITH RELAYS (MOUNT ON ROOF OR ROLL BARS)
- RPM ACTIVATED SWITCHES, ELECTRIC SHIFTERS, & NOS SYSTEMS.
- TOW TRAILER POWER LEADS & CAMPER BATTERY JUNCTION CIRCUITS
- POWER WINDOWS, POWER SEATS, POWER DOOR LOCKS, POWER TOP

 M&H ELECTRIC FABRICATORS, INC. AUTOMOTIVE WIRING SYSTEMS (562) 926-9552 www.wiringharness.com	
TITLE INSTRUCTION SHEET 4-WAY ATO ACCESSORY FUSE BLOCK KIT WITH SIDE MOUNTS AND 30MM MOUNTING RAILS	
DWG NO. 92974214	SHEET NO. 8 OF 10

TYPICAL FUSE BLOCK SCHEMATICS

THESE SCHEMATICS ARE FOR REFERENCE ONLY.
FOLLOW DEVICE RECOMMENDATIONS AS REQUIRED.

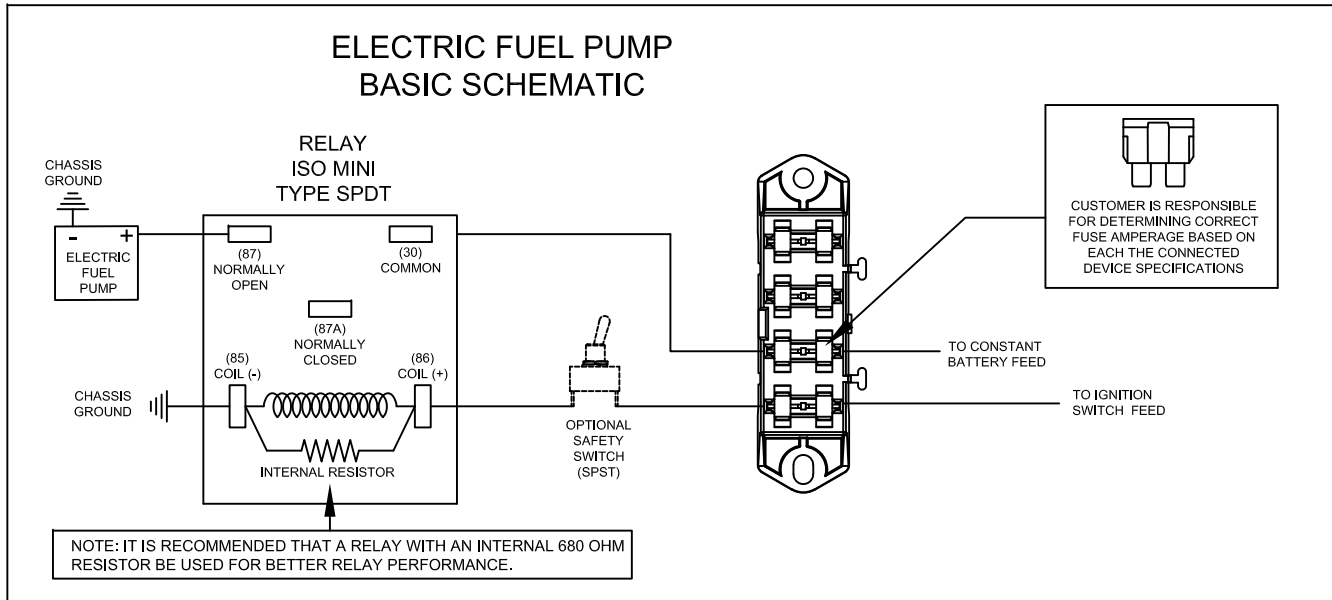
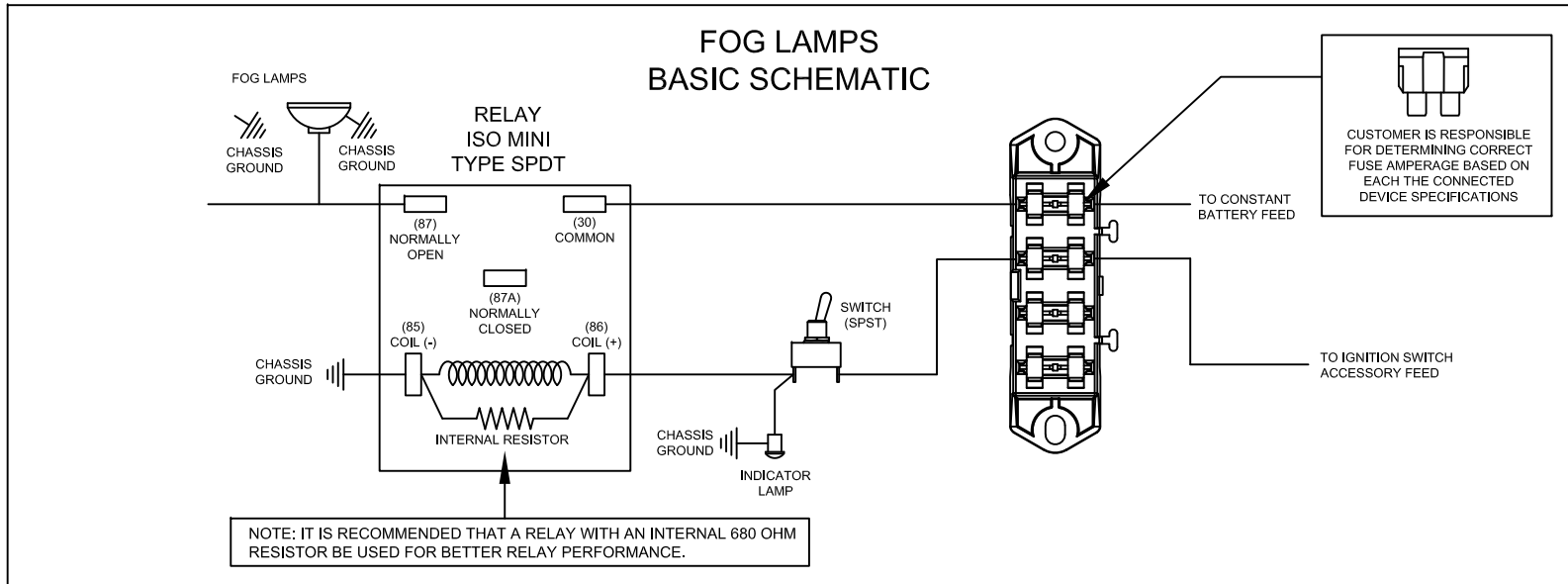

TITLE	INSTRUCTION SHEET 4-WAY ATO ACCESSORY FUSE BLOCK KIT WITH SIDE MOUNTS AND 30MM MOUNTING RAILS	
DWG NO.	92974214	SHEET NO. 9 OF 10

4-WAY ATO FUSE BLOCK WITH SIDE MOUNTS ATTACHMENT OPTIONS TO CLASSIC AUTOFUSE SERIES DASH HARNESSSES

(SEE CATALOG APPLICATIONS FOR SPECIFIC DASH HARNESS PART NUMBERS USING THESE FUSE BLOCKS)

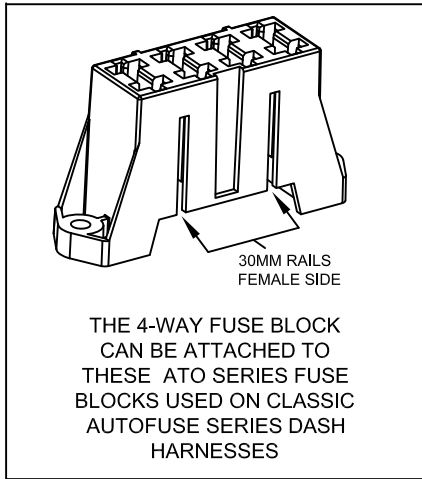

THIS ATO SERIES FUSE BLOCK IS USED ON THE FOLLOWING CAR LINES:

<p>40MM MALE MOUNTING RAILS NOT APPLICABLE</p> <p>30MM MALE MOUNTING RAILS</p>	<u>1964-67 GM "A" BODY:</u> • CHEVELLE / EL CAMINO • SKYLARK / GS • GTO / LEMANS • CUTLASS / 442
	<u>1963-67 GM "B" BODY:</u> • IMPALA • CAPRICE • BISCAYNE • BEL AIR • AND OTHER CHEVY PASSENGER MODELS
	<u>1967 GM "F" BODY:</u> • CAMARO • FIREBIRD
	<u>1967-69 "Z" BODY:</u> • CORVAIR

THIS ATO SERIES FUSE BLOCK IS USED ON THE FOLLOWING CAR LINES:

<p>40MM MALE MOUNTING RAILS NOT APPLICABLE</p> <p>40MM MALE MOUNTING RAILS NOT APPLICABLE</p> <p>40MM MALE MOUNTING RAILS NOT APPLICABLE</p> <p>30MM MALE MOUNTING RAILS</p>	<u>1968-77 GM "A" BODY:</u> • CHEVELLE / EL CAMINO • MONTE CARLO • SKYLARK / GS • GTO / LEMANS • CUTLASS / 442
	<u>1968-71 GM "B" BODY:</u> • IMPALA • CAPRICE • BISCAYNE • BEL AIR • AND OTHER CHEVY PASSENGER MODELS
	<u>1968-79 GM "F" BODY:</u> • CAMARO • FIREBIRD • 68 & 69 ALREADY COMPLETE
	<u>1968-74 GM "X" BODY:</u> • CHEVY II / NOVA
	<u>1968-78 GM "Y" BODY:</u> • CORVETTE

30MM FEMALE MOUNTING RAILS

30MM MALE MOUNTING RAILS

PART # 44302
4-WAY ATO
ACCESSORY KIT
WITHOUT SIDE MOUNTS

THIS ATO SERIES FUSE BLOCK IS USED ON THE FOLLOWING CAR LINES:

<p>40MM MALE MOUNTING RAILS NOT APPLICABLE</p> <p>30MM MALE MOUNTING RAILS</p> <p>30MM MALE MOUNTING RAILS</p>	<u>1958-62 GM "B" BODY:</u> • IMPALA • BEL AIR • BISCAYNE • CAPRICE
	<u>1962-67 GM "X" BODY:</u> • CHEVY II / NOVA
	<u>1958-67 GM "Y" BODY:</u> • CORVETTE

NOTE:
CUSTOMER MUST DETERMINE IF
THERE IS SUFFICIENT SPACE TO
ATTACH 4-WAY FUSE BLOCK TO
ATO FUSE BLOCK AFTER DASH
HARNESS HAS BEEN INSTALLED
IN VEHICLE.

ATO FUSES NOT INCLUDED IN KIT

30MM FEMALE MOUNTING RAILS

PART # 44801
5-WAY ATO
FUSE HOLDER



TITLE	INSTRUCTION SHEET 4-WAY ATO ACCESSORY FUSE BLOCK KIT WITH SIDE MOUNTS AND 30MM MOUNTING RAILS
DWG NO.	92974214
SHEET NO.	10 OF 10