

# M&H ELECTRIC FABRICATORS, INC.

## AUTOMOTIVE WIRING SYSTEMS

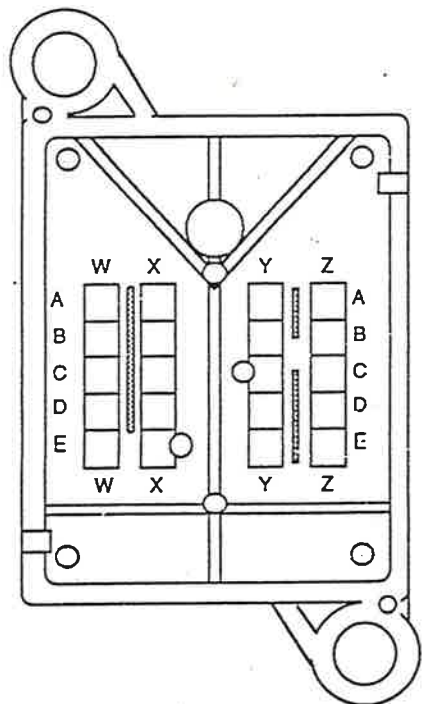

1967 FUSE BLOCK BULKHEAD CONNECTOR  
( viewed from interior side with fuse panel removed )

CONSOLE WIRING APPLICATION CHART		
wire	color	application
1	orange	Rear console light
1	orange	1967-68 gauge cluster clock
2	yellow	Low fuel indicator lamp
3	purple	Neutral safety switch
4	purple / white stripe	Neutral safety switch
5	white	Rear console light
6	light green	Neutral safety switch - backup light
7	black	Ammeter gauge
8	black / white stripe	Ammeter gauge
9	pink	Neutral safety switch - backup light
9	pink	Fuel and temperature gauge power
10	gray	Gauge lamps
11	dark green	Temperature gauge
12	tan	Fuel gauge
	black	console gauge cluster ground

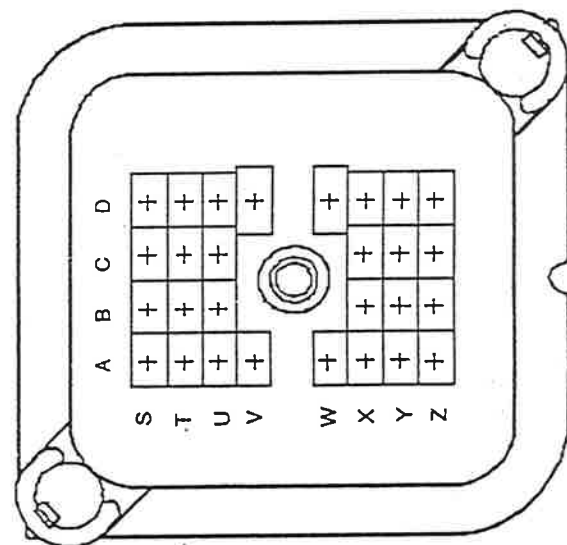

1968 - 1969 FUSE BLOCK BULKHEAD CONNECTOR  
( viewed from interior side with fuse panel removed )

ENGINE HARNESS CONNECTOR  
(viewed from fuse block bulkhead connector side )

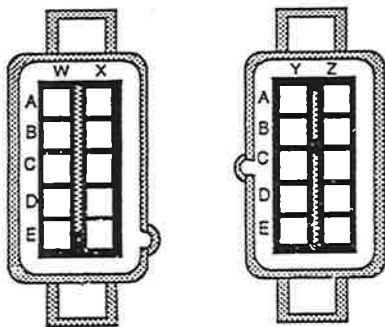

FRONT LIGHT HARNESS CONNECTOR  
(viewed from fuse block bulkhead connector side )

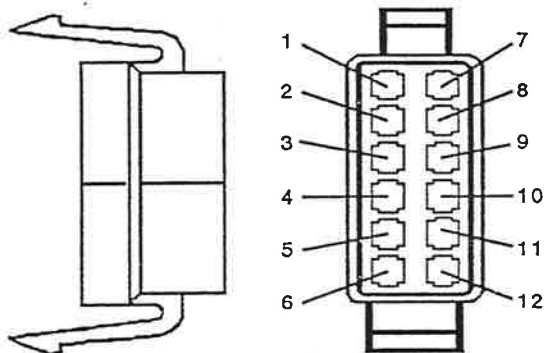

GAUGE HARNESS CONNECTOR SUPPLIED ON THE CONSOLE EXTENSION HARNESS

ENGINE HARNESS CONNECTOR  
(viewed from fuse block bulkhead connector side )

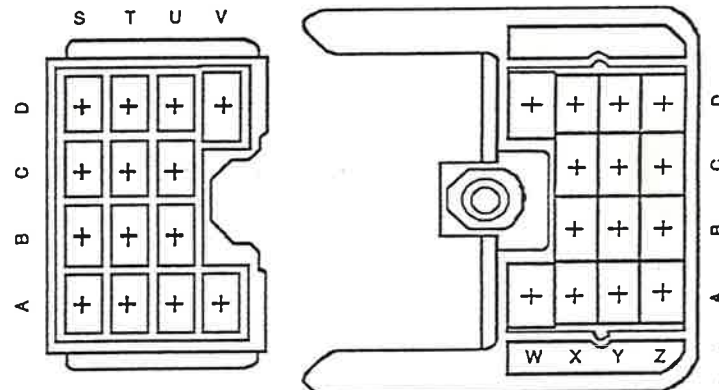

FRONT LIGHT HARNESS CONNECTOR  
(viewed from fuse block bulkhead connector side )

92963685

# PROCEDURE TO WIRE DASH/ENGINE CONSOLE GAUGE EXTENSION HARNESS

## - DASH SIDE MODIFICATIONS -

Refer to the enclosed schematics, fuse block connector, and gauge harness connector diagrams to complete the following steps:

### AMMETER GAUGE

- 1967 Connect the black wire from the gauge harness connector (location 7) to fuse block bulkhead connector location E-X. Connect the black/white wire from the gauge harness connector (location 8) to fuse block bulkhead connector location E-W.
- 1968-69 Connect the black wire from the gauge harness connector (location 7) to fuse block bulkhead connector location S-A. Connect the black/white wire from the gauge harness connector (location 8) to fuse block bulkhead connector location S-B.

### OIL PRESSURE GAUGE

Oil pressure gauges are mechanical and require an oil line to be connected from the back of the oil pressure gauge to a fitting at the rear of the engine block next to the distributor that replaces the oil pressure sending unit. Modifications to the fuseblock bulkhead connector are necessary as follows:

- 1967 (See low fuel indicator and tachometer hookup procedures.)
- 1968-69 Wiring in the dash harness fuse block bulkhead connector corresponding to this location needs no modification.

### FUEL GAUGE

- 1967-68 Unplug the speedometer cluster connector from the rear of the speedometer cluster. The connector is numbered above each of the 12 inputs. Location 1 contains a tan wire. Remove the terminal and wire from the cluster connector. This wire will be eliminated from the circuit when you are complete, but for now it should be taped out of the way. Remove the tan wire from the dash side of the rear body connector and replace it with the tan wire from location 12 of the gauge harness connector. This now routes the fuel sender wiring directly to the console mounted fuel gauge.
- 1969 Unplug the connector from the back of the dash panel mounted fuel gauge. Remove the tan wire and terminal from the connector and connect it to the tan wire from location 12 of the gauge harness connector using the supplied locking connector body. This now routes the fuel sender wiring directly to the console mounted fuel gauge.

### LOW FUEL INDICATOR

- 1967 Unplug the speedometer cluster connector from the rear of the speedometer cluster. The connector is numbered above each of the 12 inputs. Location 8 contains a blue/white wire. Remove the terminal and wire from the cluster connector. Trace the wire to the fuse block bulkhead connector and remove both the terminal and wire from location D-Z. The light connected to the yellow wire from location 2 of the gauge harness connector must be plugged directly into the speedometer cluster chassis in the hole underneath the plastic circuit board in the low fuel light position.
- NOTE:** Be sure your low fuel circuit is one originally designed for use with the 1967 gauge cluster. The 1968-69 low fuel indicator is different and cannot be used in 1967.
- 1968 Unplug the speedometer cluster connector from the rear of the speedometer cluster. The connector is numbered above each of the 12 inputs. Location 8 contains a blue/white wire. Replace this terminal and wire with the yellow wire and terminal from location 2 of the gauge harness connector. Trace the blue/white wire to the fuse block bulkhead connector and remove both the terminal and wire from location B-Z. This wire can be taped out of the way as it's original use for the oil pressure sender circuit is now dead.
- NOTE:** Be sure your low fuel circuit is one originally designed for use with the 1968-69 gauge cluster. The 1967 low fuel indicator is different and cannot be used in 1968-69.
- 1969 The low fuel indicator light occupies the light socket position next to the left turn signal indicator. Normally this socket is empty for non-gauge equipped cars. Plug the yellow wire from location 2 of the gauge harness connector into one of the low fuel light lamp socket terminal holders. Transfer the pink lamp socket wire and terminal from the temperature indicator lamp to the other low fuel light lamp socket terminal holder.

### TEMPERATURE GAUGE

- 1967 Unplug the speedometer cluster connector from the rear of the speedometer cluster. The connector is numbered above each of the 12 inputs. Location 2 contains two dark green wires. Remove the terminal and wire from the cluster connector and tape them aside. Originally, one of these wires was routed to the fuse block bulkhead connector and the other to the ignition switch. Trace the wire to the fuse block bulkhead connector and remove both the terminal and wire from location C-Z. Trace the wire to the ignition switch and disconnect both the wire and terminal from the ignition switch. This now removes the original dash mounted temperature warning light circuit from service. Connect the dark green wire from the gauge harness connector (location 11) to fuse block bulkhead connector location C-Z. This now routes the temperature sender unit lead wire directly from the fuse block bulkhead connector to the gauge harness connector.
- 1968 Unplug the speedometer cluster connector from the rear of the speedometer cluster. The connector is numbered above each of the 12 inputs. Location 2 contains two dark green wires. Remove the terminal and wire from the cluster connector. Disconnect these wires from the plug and tape them aside. Originally, one of these wires was routed to the fuse block and the other to the ignition switch. Trace the wire to the fuse block bulkhead connector and remove both the terminal and wire from location C-T. Trace the wire to the ignition switch and disconnect both the wire and terminal from the ignition switch. This now removes the original dash mounted temperature warning light circuit from service. Connect the dark green wire from the gauge harness connector (location 11) to fuse block bulkhead connector location C-T. This now routes the temperature sender unit lead wire directly from the fuse block bulkhead connector to the gauge harness connector.
- 1969 Locate the two dark green wires going into the temperature warning light (second light from the left in the warning light assembly located to the right of the steering wheel). Disconnect these wires from the light socket and tape them aside. Originally, one of these wires was routed to the fuse block bulkhead connector and the other to the ignition switch. Trace the wire to the fuse block bulkhead connector and remove both the terminal and wire from location C-T. Trace the wire to the ignition switch and disconnect both the wire and terminal from the ignition switch. This now removes the original dash mounted temperature warning light circuit from service. Connect the dark green wire from the gauge harness connector (location 11) to fuse block bulkhead connector location C-T. This now routes the temperature sender unit lead wire directly from the fuse block bulkhead connector to the gauge harness connector.

## POWER CONNECTIONS

1967-69 Plug the orange wire from location 1 of the gauge harness connector to a constant battery power terminal on the face of the fuse panel. Plug the pink wire from location 9 of the gauge harness connector to an ignition power terminal on the face of the fuse panel.

## INSTRUMENT LIGHTS

1967-69 Plug the gray wire from location 10 of the gauge harness connector to the instrument light terminal on the face of the fuse panel.

## CONSOLE COURTESY LIGHT

1967-69 Conversions starting from a console automatic will automatically handle the console courtesy light circuit. In all other cases, there will be a separate white wire originating from location 5 of the gauge harness connector. This wire will be used to replace the white wire from the dash side of the rear body connector. The wire just removed will be plugged into the white jumper wire using the supplied locking connector body. This now activates the console courtesy light circuit.

## AUTOMATIC TRANSMISSION

1967-69 Connect the purple, purple/white, and light green wires for the neutral safety switch (if applicable) as per the schematic of the year in question.

## MISCELLANEOUS

1967-68 Unplug the brown wire from the speedometer cluster connector location 11 and tape the end to prevent grounding. This wire was originally used for the "GEN" warning light which is not present in the speedometer/tachometer cluster.

## TACHOMETER

1967 Unplug the speedometer cluster connector from the rear of the speedometer cluster. The connector is numbered above each of the 12 inputs. Insert the cluster connector terminal end of the brown wire taped into the extension harness into location 1 of the speedometer cluster connector. Insert the other end of this wire into fuse block bulkhead connector location D-Z.

1968 Unplug the speedometer cluster connector from the rear of the speedometer cluster. The connector is numbered above each of the 12 inputs. Insert the cluster connector terminal end of the brown wire taped into the extension harness into location 2 of the speedometer cluster connector. Insert the other end of this wire into fuse block bulkhead connector location A-X. Plug the orange wire with the single pin type connector to the clock power terminal on the back of the tachometer.

1969 The tachometer connector is already wired into the new gauge extension harness and is connected as follows:

- Connect the black wire from the tachometer connector to a good ground.
- Plug the pink wire from the tachometer connector to an ignition power terminal on the face of the fuse panel.
- Connect the brown wire from the tachometer connector to fuse block bulkhead connector location A-X.

## - ENGINE SIDE MODIFICATIONS -

Refer to the enclosed schematics, fuse block connector, and gauge harness connector diagrams to complete the following steps:

## AMMETER GAUGE

1967 Select the long black wire with the orange fusible link. Connect the fusible link end to the positive battery junction block located behind the battery. Plug the other end of this wire into location E-X of the front light harness connector. Select the long black/white wire with the orange fusible link. Connect the fusible link end to one of the positive battery screws on the horn relay. Plug the other end of this wire into location E-W of the front light harness connector.

1968-69 Select the long black wire with the orange fusible link. Connect the fusible link end to the positive battery junction block located behind the battery. Plug the other end of this wire into location S-A of the front light harness connector. Select the long black/white wire with the orange fusible link. Connect the fusible link end to one of the positive battery screws on the horn relay. Plug the other end of this wire into location S-B of the front light harness connector.

## OIL PRESSURE GAUGE

Oil pressure gauges are mechanical and require an oil line to be connected from the back of the oil pressure gauge to a fitting at the rear of the engine block next to the distributor that replaces the oil pressure sending unit. When the old oil pressure sending unit is removed, the blue wire originally connected to this sending unit must be disconnected from the engine harness fuse block connector as follows:

1967 Remove the twin lock terminal from engine harness connector location D-Z and cut off the terminal. Disconnect the blue wire from the oil pressure sending unit, pull it through the harness and discard it.

1968-69 Remove the male terminal from engine harness connector location B-Z and cut off the terminal. Disconnect the blue wire from the oil pressure sending unit, pull it through the harness and discard it.

## TEMPERATURE GAUGE

1967-69 A new dark green temperature gauge wire is provided should it be necessary to replace the existing wire. All warning light and gauge equipped cars used the same wiring to the temperature sending unit. The difference in operation was due to the difference in the function of the sending unit and not the wiring. Original GM sending units are recommended, however replacement units are made by most major after market component suppliers. (i.e. FILKO 2004, SORENSON TS-4).

## FUEL GAUGE

No electrical modifications are required.

## TACHOMETER

1967 Select the brown wire with the right angle spade terminal on one end and the twin lock terminal on the other. Connect the twin lock terminal to location D-Z of the engine harness connector. Connect the right angle spade terminal to the distributor ( - ) side of the ignition coil.

1968-69 Select the brown wire with the right angle spade terminal on one end and a flat male terminal on the other. Connect the flat male terminal to location A-X of the engine harness connector. Connect the right angle spade terminal to the distributor ( - ) side of the ignition coil.

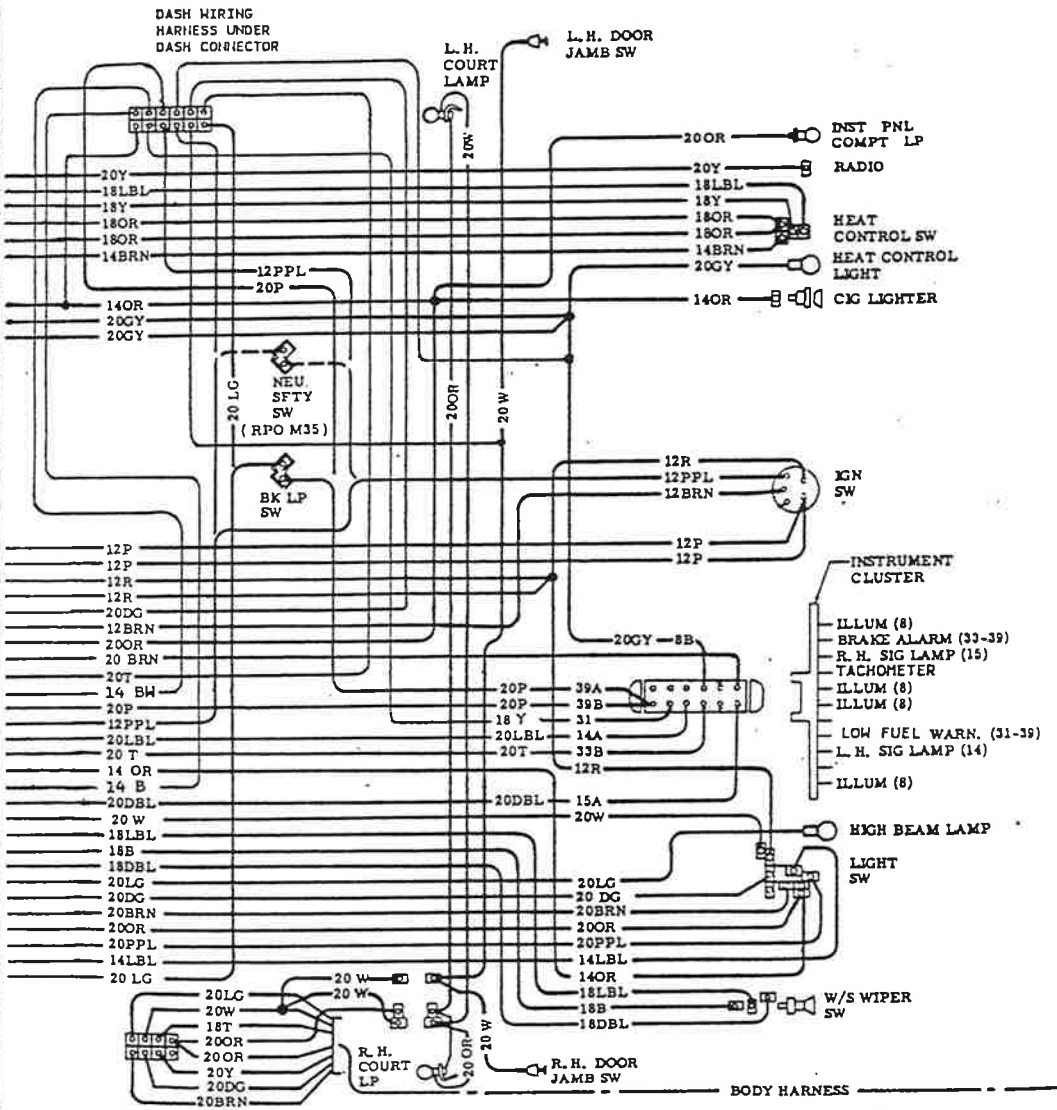
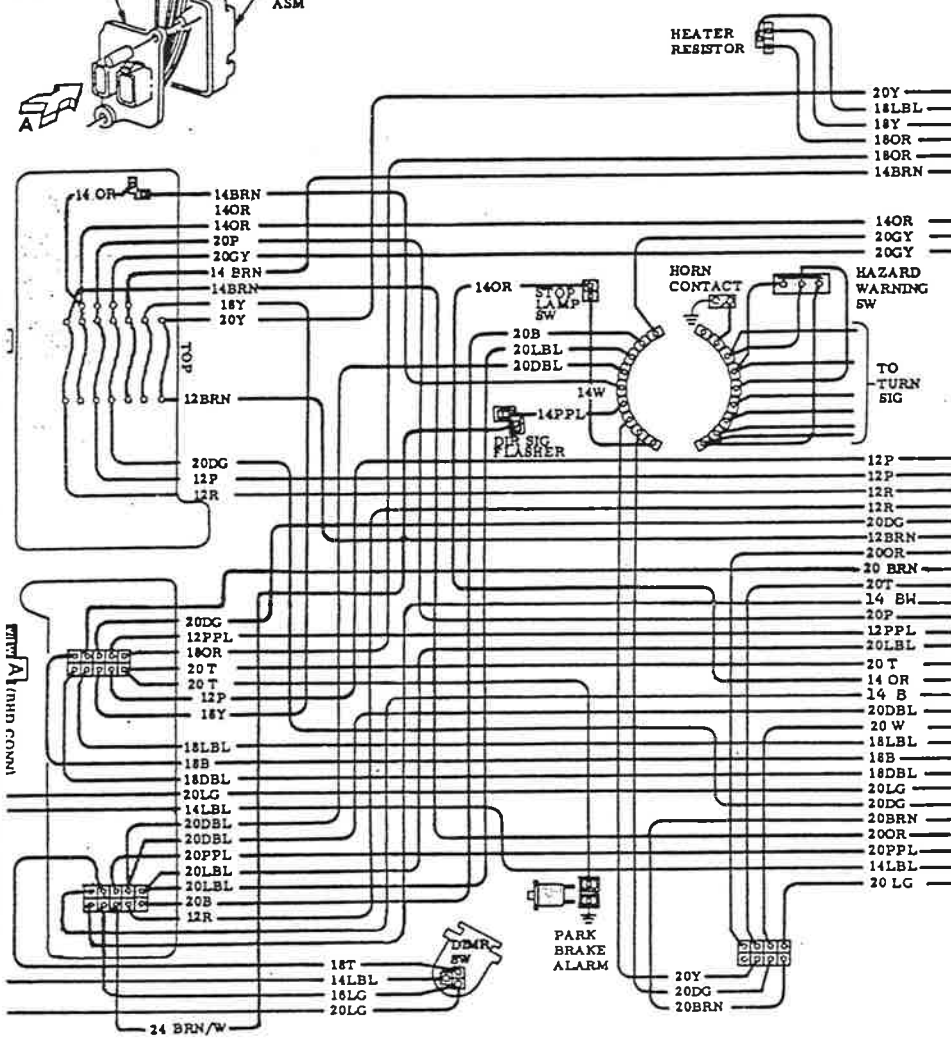
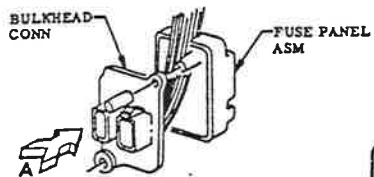

1967 - FUSE PANEL

1967 - INSTRUMENT PANEL

92963685

676717  
676719

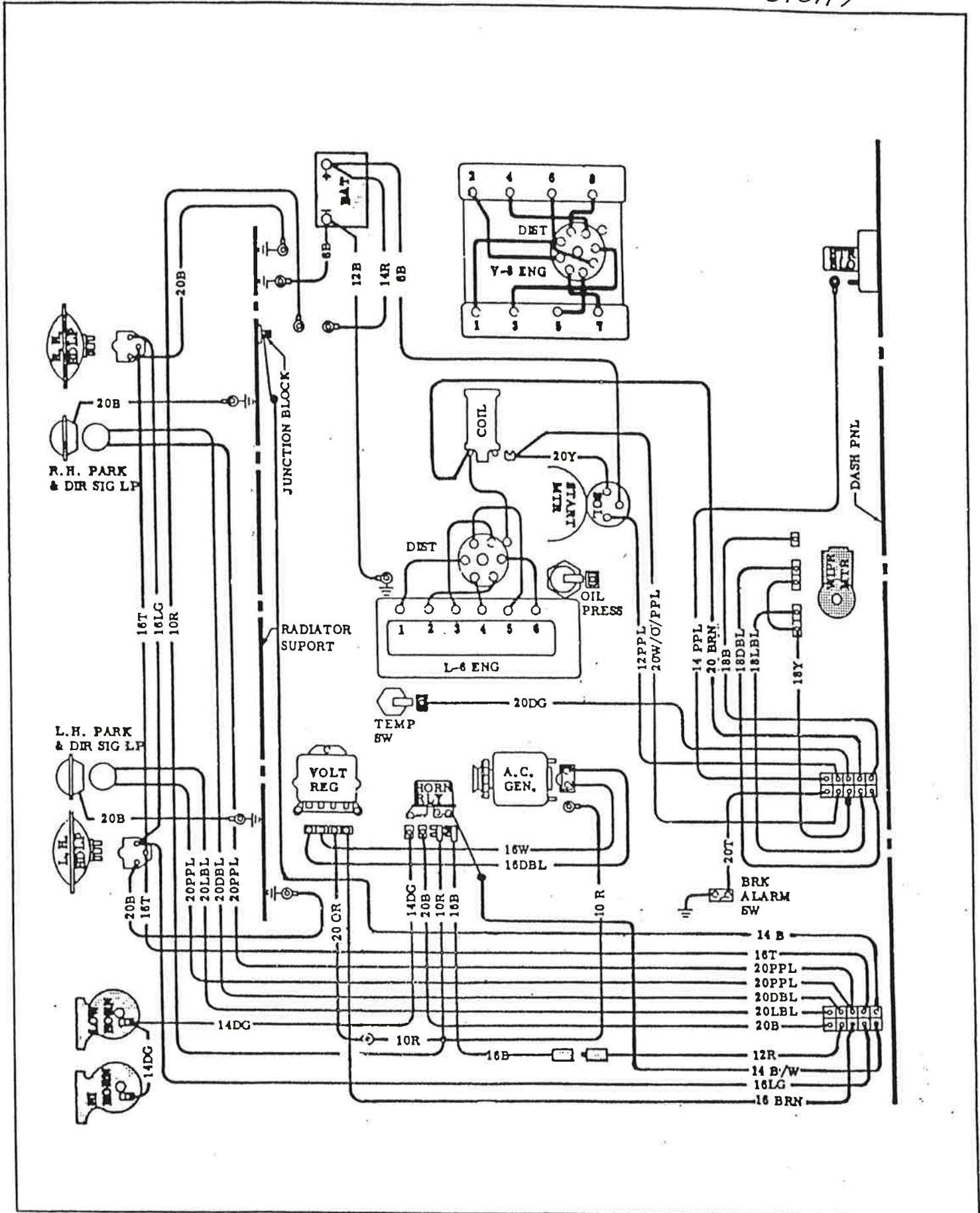

92963685

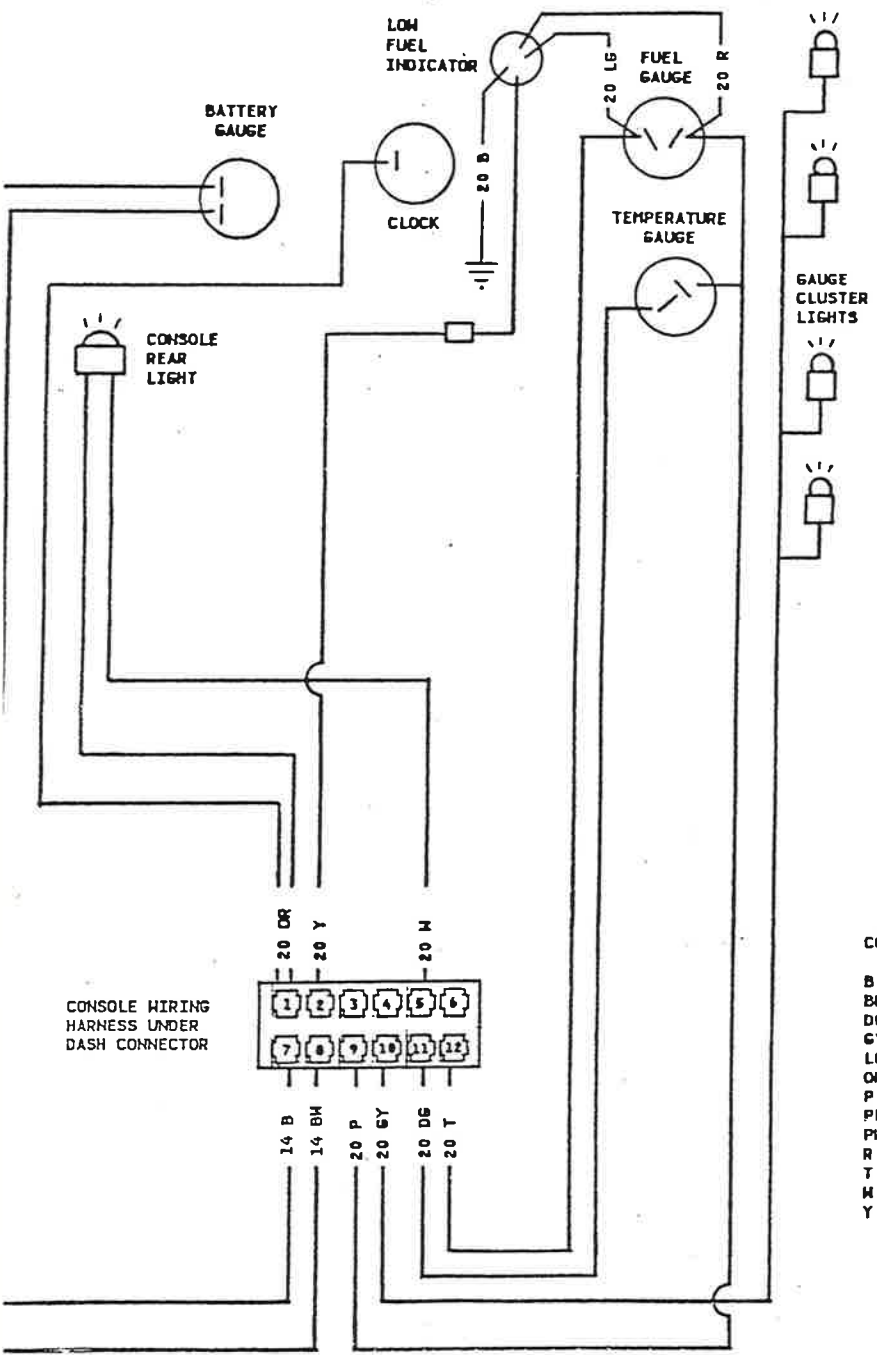

COLOR CODE CHART

B = BLACK  
 BH = BLACK/WHITE  
 DG = DARK GREEN  
 GY = GRAY  
 LG = LIGHT GREEN  
 OR = ORANGE  
 P = PINK  
 PL = PURPLE  
 PH = PURPLE/WHITE  
 R = RED  
 T = TAN  
 M = WHITE  
 Y = YELLOW

1967 CONSOLE WIRING  
 MANUAL TRANSMISSION WITH CONSOLE GAUGES

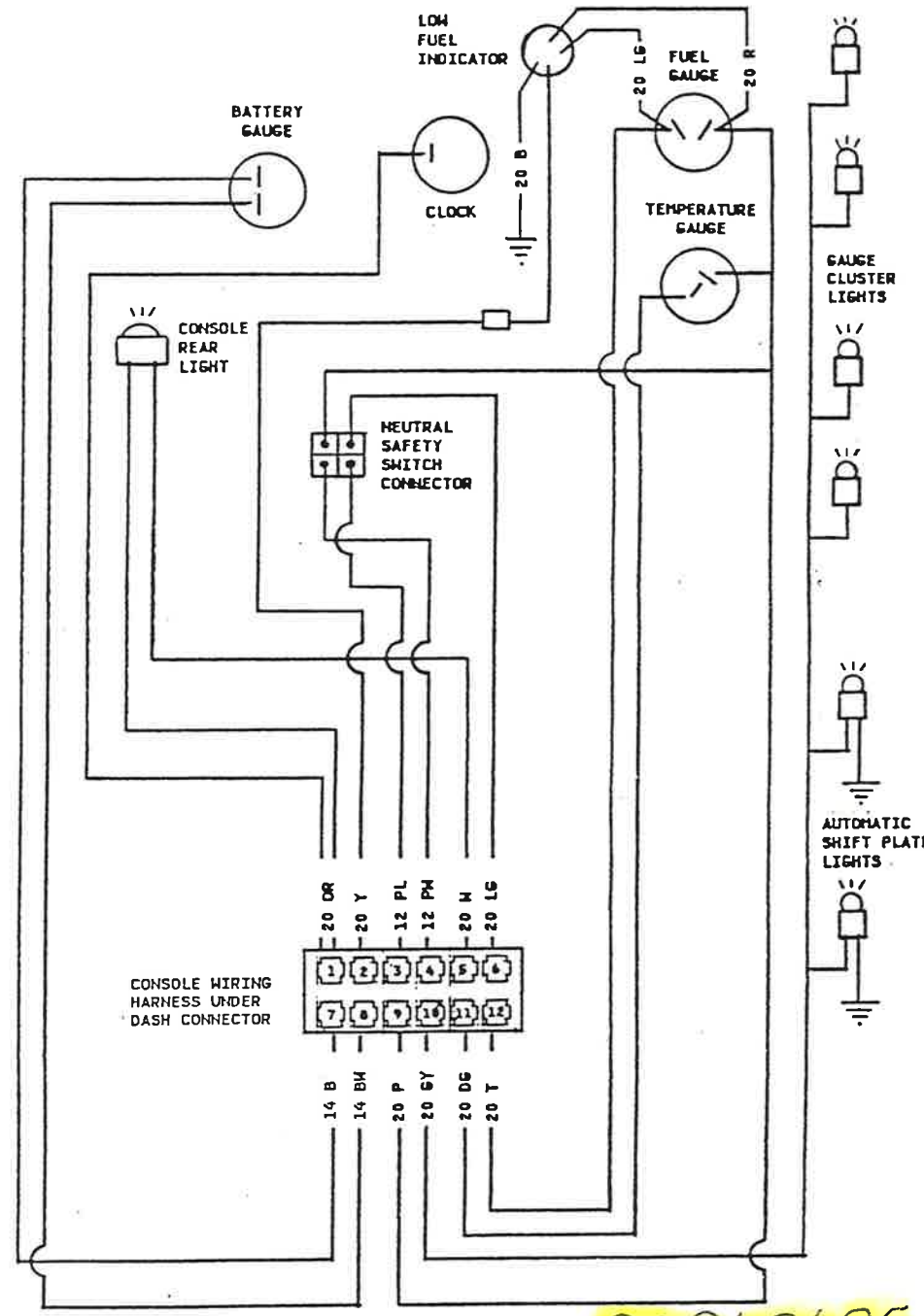

1967 CONSOLE WIRING  
 AUTOMATIC TRANSMISSION WITH CONSOLE GAUGES

92963685