

**TO OUR VALUED CUSTOMER:  
PLEASE READ ALL NOTES BEFORE BEGINNING INSTALLATION**

WIRE	GA.	COLOR	NOTES
1A	12	RED / WHITE	SEE PAGE 8
1B	12	RED / WHITE	SEE PAGE 8
1C	10	RED / WHITE	SEE PAGE 8
1D	12	RED / WHITE	SEE PAGE 8
1E	10	RED / WHITE	
1F	10	RED / WHITE	
2A	12	RED	
2B	12	RED	SEE PAGE 8
2C	12	RED	
2D	12	RED	
2E	12	RED	
2F	14	RED	SEE PAGE 8
3A	12	PINK	
3B	12	PINK	
3C	12	PINK	SEE PAGE 8
3D	14	PINK	SEE PAGE 8
3E	14	PINK	SEE PAGE 8
4	12	BROWN	
4B	14	BROWN	SEE PAGE 8
4C	18	BROWN	SEE PAGE 8
5	12	PURPLE	
6	12	PURPLE	
6A	12	PURPLE	
8A	18	GRAY	
8B	18	GRAY	
8C	18	GRAY	SEE PAGE 8
8D	18	GRAY	SEE PAGE 8
9A	18	BROWN	

WIRE	GA.	COLOR	NOTES
9B	18	BROWN	
10	14	LIGHT BLUE	
11A	16	LIGHT GREEN	
11B	18	LIGHT GREEN	
12	18	TAN	
14A	18	LIGHT BLUE	
14B	18	LIGHT BLUE	
15A	18	DARK BLUE	
15B	18	DARK BLUE	
16	18	PURPLE	
17	18	WHITE	
18	18	YELLOW	
19	18	DARK GREEN	
21	18	WHITE	
24	18	LIGHT GREEN	
24A	18	LIGHT GREEN	
27	16	BROWN	
27A	16	BROWN	SEE PAGE 8
28	18	BLACK	
29	12	DARK GREEN	
30	18	TAN	
33A	18	TAN	
33B	18	TAN	
35	18	DARK GREEN	
39	18	PINK	
39A	16	PINK	SEE PAGE 8
39B	16	PINK	SEE PAGE 8

WIRE	GA.	COLOR	NOTES
39C	14	PINK	SEE PAGE 8
39D	14	PINK	
39M	18	PINK	
40A	18	ORANGE	
40B	16	ORANGE	
40C	18	ORANGE	
40D	18	ORANGE	SEE PAGE 8
40E	14	ORANGE	SEE PAGE 8
43	18	YELLOW	SEE PAGE 8
44	16	DARK GREEN	
50	14	BROWN	
50A	14	BROWN	SEE PAGE 8
75	18	DARK GREEN	
75A	18	DARK GREEN	
91	18	BLACK	
92	18	LIGHT BLUE	
93A	18	YELLOW	
93B	18	YELLOW	
94	18	DARK BLUE	
130	24	RESISTANCE BROWN / WHITE	
141	18	BROWN / WHITE	
150	18	BLACK	
200	12	LIGHT GREEN / BLACK	
201	12	DARK GREEN / RED	
202	12	BLACK / RED	
203	12	RED / BLACK	
204	10	ORANGE / BLACK	

THANK YOU FOR PURCHASING THIS CLASSIC AUTOFUSE SERIES DASH HARNESS. THIS IS THE ONLY FACTORY PLUG & PLAY OEM STYLE DASH HARNESS WITH STATE-OF-THE-ART AUTOFUSE SERIES FUSES. FOR ANY QUESTIONS CONCERNING INSTALLATION OF THIS HARNESS PLEASE CALL OUR TECHNICAL SUPPORT LINE AT (562) 926-9552.

OPTIONAL RELAY CONNECTORS AND TERMINAL KITS, FUSE AND FLASHER KITS, FRONT OF FUSE BLOCK ACCESSORY CONNECTOR AND TERMINAL KITS ARE AVAILABLE SEPARATELY. CALL YOUR AUTHORIZED M&H ELECTRIC DEALER OR OUR DIRECT DIAL LINE ABOVE FOR ASSISTANCE WITH THESE KITS AND MANY OTHER ELECTRICAL PRODUCTS FOR YOUR CLASSIC CAR OR TRUCK.

ALL ROUTING IS LIKE ORIGINAL DASH HARNESS EXCEPT ACCESSORY WIRES AND TURN SIGNAL FLASHER. SEE STEP 2 ON PAGE 2 FOR REMOVAL OF BULKHEAD CONNECTOR BEFORE BEGINNING INSTALLATION OF DASH HARNESS. IT IS RECOMMENDED THAT YOU PURCHASE A FACTORY ASSEMBLY INSTRUCTION MANUAL (WHEN AVAILABLE) TO ASSIST IN ROUTING HARNESSES THROUGHOUT THE VEHICLE. PROCEED TO INSTALL DASH HARNESS EXCEPT THE 6 NEW ACCESSORY WIRES. THESE WIRES WILL BE COVERED IN STEP 7 OF PAGE 2.

**CAUTION:** ACCESSORY WIRES MUST NOT BE LEFT BARE. SEE CAUTION BELOW IF ANY OF THE ACCESSORY WIRES WILL NOT BE USED.

**NOTE:** ALL CONNECTORS ON THESE INSTRUCTION SHEETS ARE VIEWED FROM THE MATING END VIEW OPPOSITE THE WIRE ENTRY SIDE UNLESS OTHERWISE SPECIFIED.

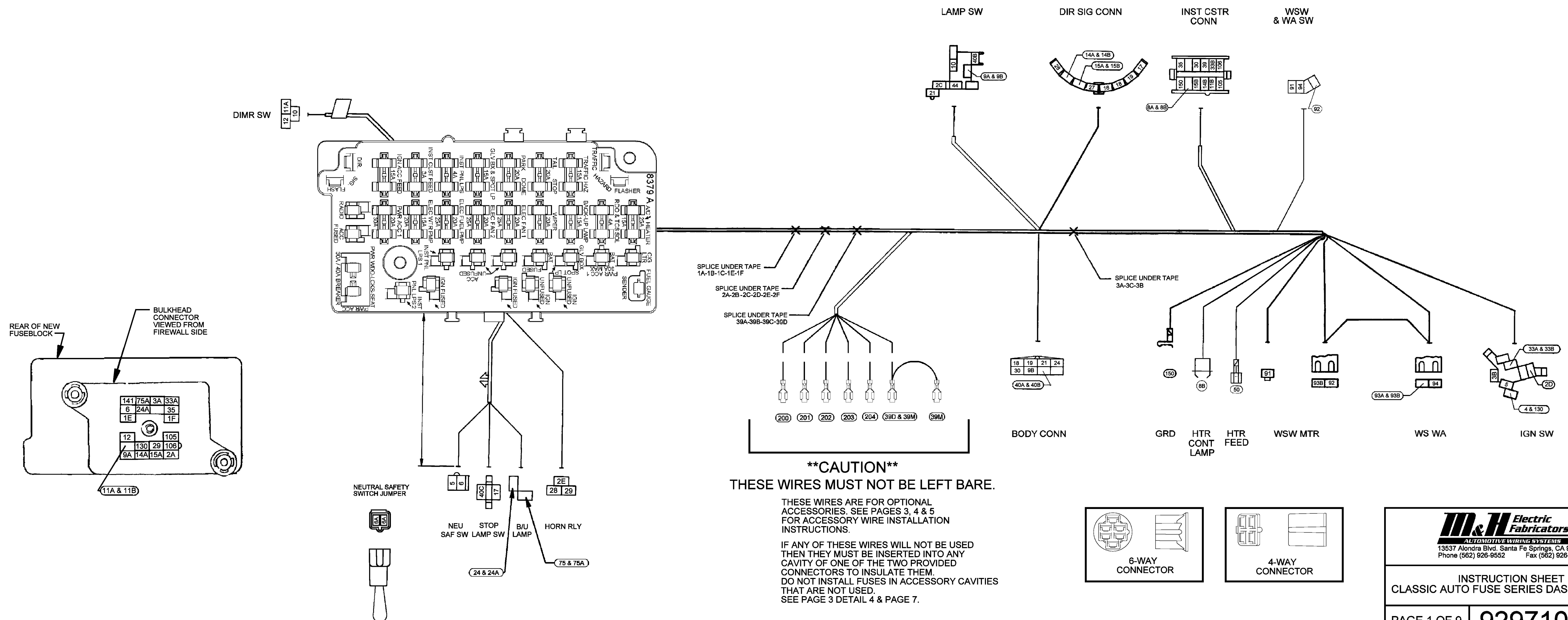

**M&H Electric Fabricators, Inc.**  
AUTOMOTIVE WIRING SYSTEMS  
13537 Alondra Blvd. Santa Fe Springs, CA 90670  
Phone (562) 926-9552 Fax (562) 926-9572

---

INSTRUCTION SHEET  
CLASSIC AUTO FUSE SERIES DASH HARNESS

---

PAGE 1 OF 9 **92971043** SIZE  
**B**

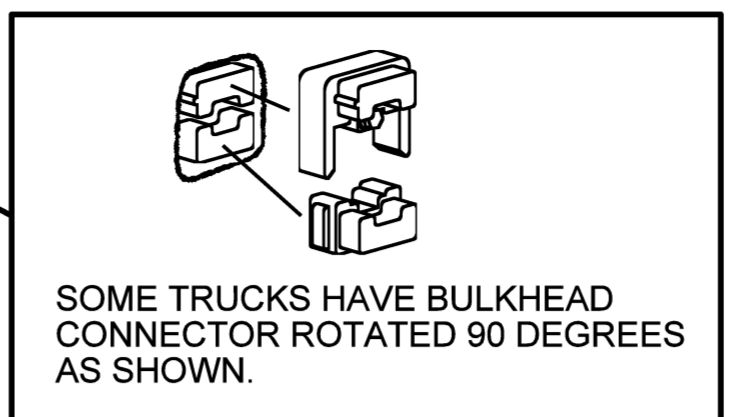
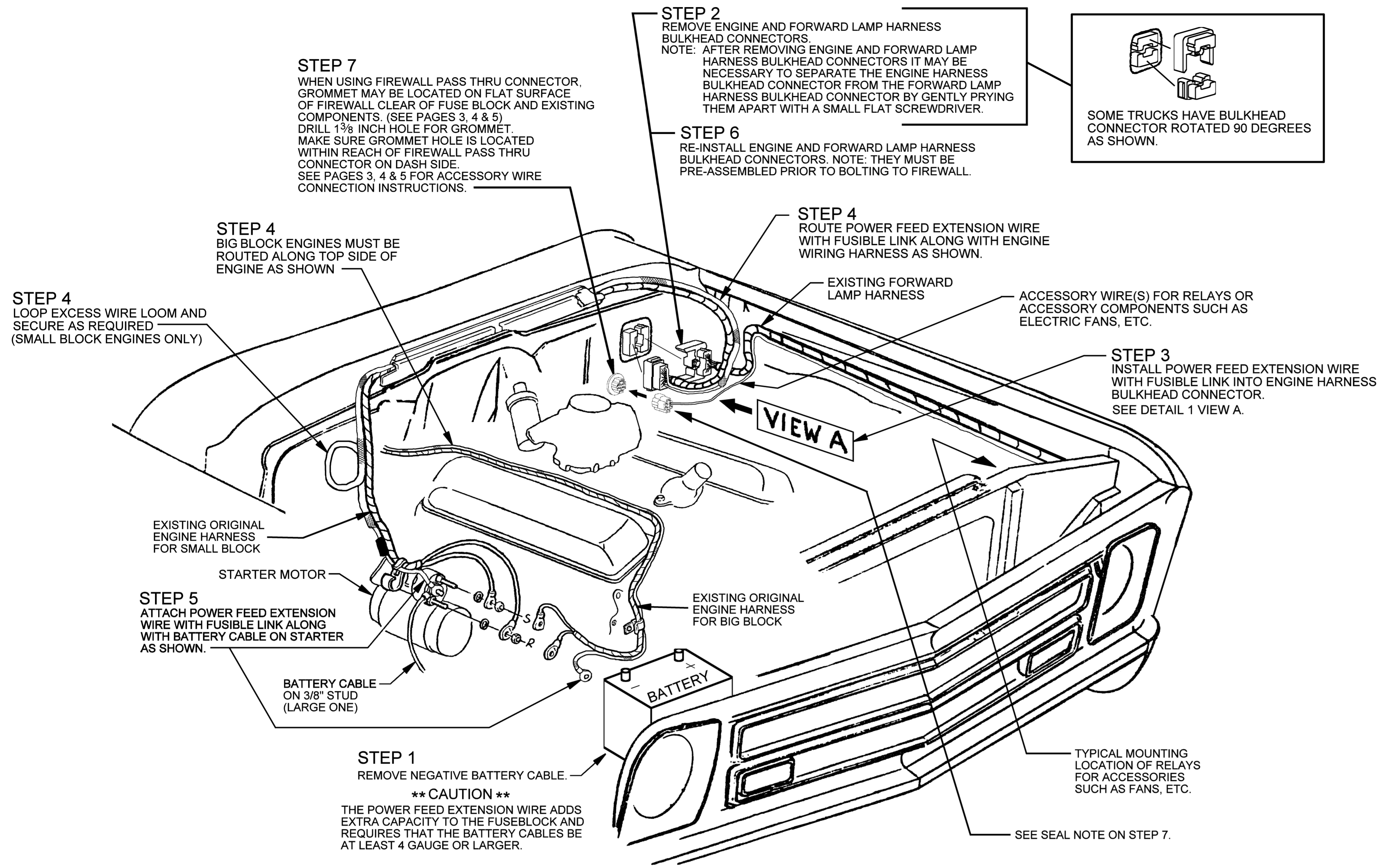

**STEP 1:**  
REMOVE NEGATIVE BATTERY CABLE.

**STEP 2:**  
REMOVE FORWARD LAMP HARNESS AND ENGINE HARNESS BULKHEAD CONNECTORS BY REMOVING ATTACHING BOLT.  
NOTE: AFTER REMOVING ENGINE AND FORWARD LAMP HARNESS BULKHEAD CONNECTORS IT MAY BE NECESSARY TO SEPARATE THE ENGINE HARNESS BULKHEAD CONNECTOR FROM THE FORWARD LAMP HARNESS BULKHEAD CONNECTOR BY GENTLY PRYING THEM APART WITH A SMALL FLAT SCREWDRIVER.

**STEP 3:**  
INSERT THE POWER FEED EXTENSION WIRE WITH FUSIBLE LINK INTO THE APPROPRIATE CAVITIES ON THE ENGINE HARNESS BULKHEAD CONNECTOR. SEE DETAIL 1 VIEW A.  
NOTE: IT MAY BE NECESSARY TO CLEAN THE CAVITIES IN THE BULKHEAD CONNECTOR WITH A SMALL SCREWDRIVER AND RE-SEAL WITH BLACK SILICONE AFTER INSTALLATION OF POWER FEED WIRE.

**STEP 4:**  
ROUTE POWER FEED EXTENSION WIRE WITH FUSIBLE LINK ALONG WITH ENGINE WIRING HARNESS AS SHOWN IN DIAGRAM.  
NOTE: SMALL BLOCK ENGINES ARE ROUTED DOWN THE BACK SIDE OF THE ENGINE AND THE EXCESS WIRE FROM THE POWER FEED EXTENSION WIRE MUST BE LOOPED AND SECURED AS SHOWN. USE CAUTION NOT TO KINK LOOM AND KEEP AWAY FROM EXHAUST OR HEAT. BIG BLOCK ENGINES ARE ROUTED OVER THE TOP ALONG SIDE THE VALVE COVER WITH NO EXCESS WIRE AS SHOWN. CAREFULLY ROUTE BELOW EXHAUST MANIFOLD BY OIL PAN RAIL TO STARTER. SECURE IF NECESSARY.

**CAUTION:** THE POWER FEED CIRCUIT ADDS EXTRA CAPACITY TO THE NEW FUSEBLOCK AND REQUIRES THAT THE VEHICLE BATTERY CABLE BE AT LEAST 4 GAUGE OR LARGER.

**STEP 5:**  
INSTALL RING TERMINAL END OF POWER FEED EXTENSION WIRE WITH FUSIBLE LINK ONTO STARTER BATTERY POST (LARGE ONE) WITH BATTERY CABLE AS SHOWN.

**STEP 6:**  
RE-INSTALL ENGINE HARNESS AND FORWARD LAMP HARNESS BULKHEAD CONNECTORS ONTO DASH BULKHEAD CONNECTOR ON FIREWALL.  
NOTE: DO NOT RE-INSTALL NEGATIVE BATTERY CABLE UNTIL ALL ACCESSORIES HAVE BEEN INSTALLED OR ADDRESSED IN PRECEDING PAGES.

**STEP 7:**  
THERE ARE 3 WAYS TO USE THE NEW ACCESSORY CONNECTORS & WIRES ON YOUR NEW CLASSIC AUTOFUSE SERIES DASH HARNESS:

1. YOU CAN USE THE 6-WAY CONNECTOR AS AN IN-LINE STYLE WHEN NO WIRES WILL BE PASSING THROUGH THE FIREWALL TO THE ENGINE COMPARTMENT.
2. YOU CAN USE THE 6-WAY CONNECTOR WITH THE GROMMET AS A PANEL MOUNT STYLE WHEN ALL THE WIRES WILL PASS THROUGH THE FIREWALL TO THE ENGINE COMPARTMENT.
3. YOU CAN USE THE 6-WAY CONNECTOR WITH THE GROMMET AS A PANEL MOUNT STYLE AND THE 4-WAY CONNECTOR AS AN IN-LINE CONNECTOR WHEN SOME WIRES WILL PASS THROUGH THE FIREWALL AND SOME WIRES WILL BE USED AS IN-LINE UNDER THE DASH.

**SEAL NOTE:** SEAL ANY UNUSED CAVITIES ON THE ENGINE SIDE OF THE 6-WAY CONNECTOR WITH SILICONE.

INSTALL THE 6-WAY CONNECTOR AND GROMMET INTO THE FIREWALL BY DRILLING A 1" HOLE IN THE FIREWALL AND INSTALLING GROMMET. MAKE SURE GROMMET HOLE IS LOCATED WITHIN REACH OF 6-WAY ACCESSORY HARNESS CONNECTOR ON DASH HARNESS BY SCREWING THE NEW FUSEBLOCK IN PLACE FIRST TO DETERMINE THE LENGTH AND POSITION OF THE ACCESSORY WIRES AND CONNECTORS.

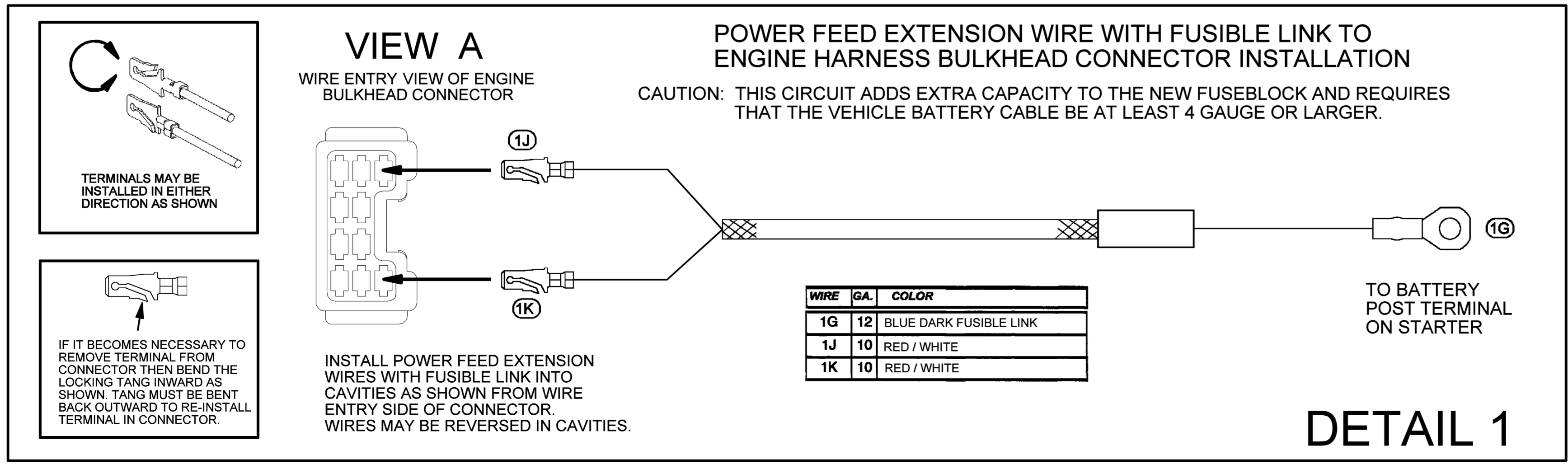





**M&H Electric Fabricators, Inc.**  
AUTOMOTIVE WIRING SYSTEMS  
13537 Alondra Blvd. Santa Fe Springs, CA 90670  
Phone (562) 926-9552 Fax (562) 926-9572

## DEVICE WIRE ASSEMBLES

SEE  
DETAIL  
1 & 2

WIRE	GA.	COLOR
200A	12	LIGHT GREEN / BLACK
201A	12	DARK GREEN / RED
202A	12	BLACK / RED
203A	12	RED / BLACK
204A	10	ORANGE / BLACK

- (200A)  TO RELAY FOR ELECTRIC WATER PUMP
- (201A)  TO RELAY FOR ELECTRIC FUEL PUMP
- (202A)  TO RELAY FOR SINGLE ELECTRIC RADIATOR FAN
- (203A)  TO RELAY FOR SECOND ELECTRIC RADIATOR FAN
- (204A)  FROM POWER ACCESSORY CIRCUIT BREAKER

THESE WIRES ARE PROVIDED TO REACH RELAYS MOUNTED IN THE MOST COMMON MOUNTING LOCATIONS. WIRES FROM RELAYS TO ACTUAL ACCESSORIES ARE NOT PROVIDED AND ARE THE RESPONSIBILITY OF THE CUSTOMER.

SEE  
DETAIL  
1 & 2

WIRE	GA.	COLOR
39N	14	PINK
39P	18	PINK
39R	18	PINK
39S	18	PINK

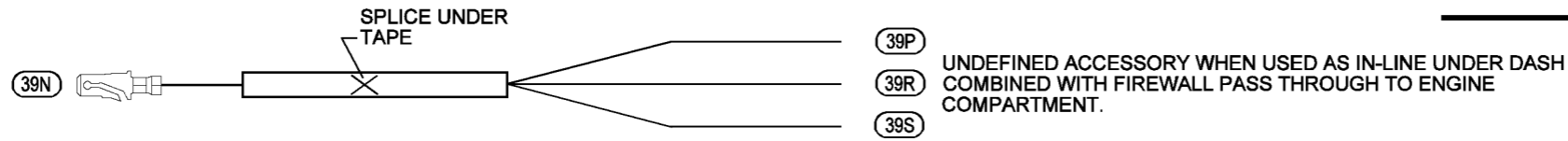

SEE  
DETAIL  
1 & 2

WIRE	GA.	COLOR
39E	14	PINK
39F	18	PINK
39G	18	PINK
39H	18	PINK
39J	18	PINK
39K	18	PINK
39L	18	PINK

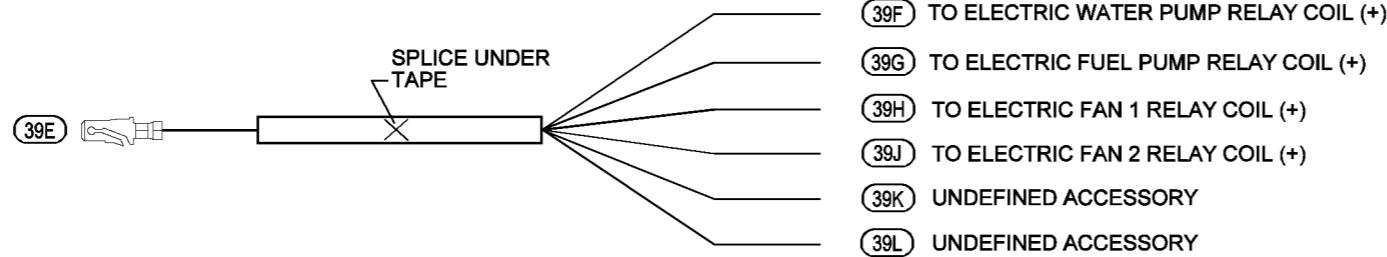

IGNITION POWER WITH SWITCH IN RUN POSITION ONLY. USED TO POWER RELAY COILS FOR ACCESSORIES WHEN IGNITION SWITCH IS TURNED ON. SEE PAGES 4 & 5. ALL WIRES ARE THE SAME AND CAN BE INTERCHANGED.

**\*\*CAUTION\*\***  
THESE WIRES ARE LIVE  
UNUSED WIRES MUST BE CUT OFF AT THE END OF TAPE OR INSULATE THE ENDS OF THE WIRES.

## IGNITION FEED WIRE ASSEMBLY

THIS 6-WAY CONNECTOR IS USED TO PASS WIRES THROUGH THE FIREWALL TO THE ENGINE COMPARTMENT OR IT CAN BE USED AS AN IN-LINE CONNECTOR UNDER DASH WITHOUT THE GROMMET.

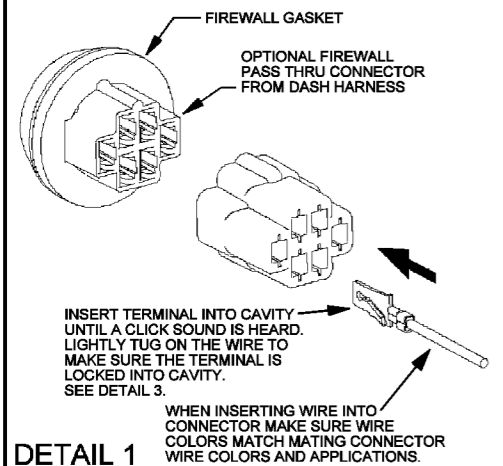

USE THIS 4-WAY CONNECTOR AS AN UNDER DASH IN-LINE CONNECTOR FOR WIRES THAT DO NOT HAVE TO PASS THROUGH THE FIREWALL.

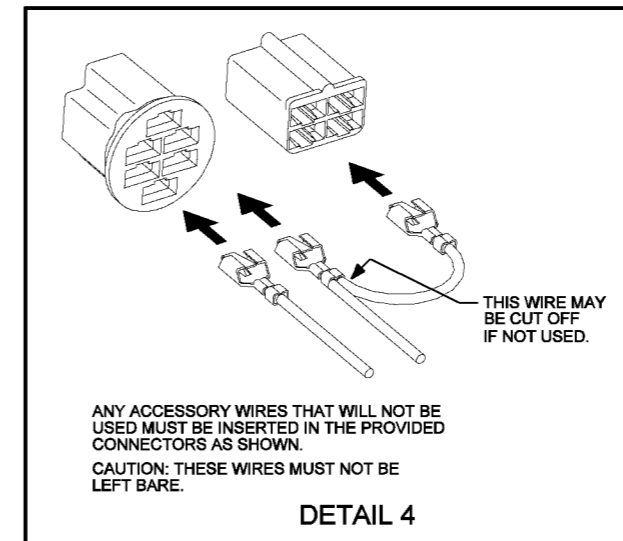
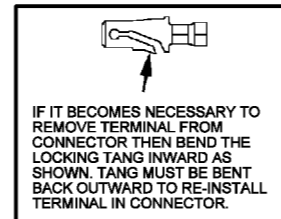
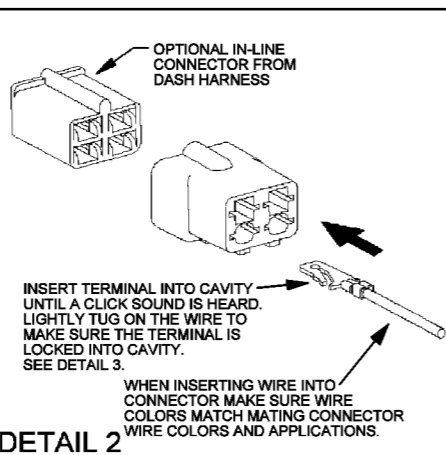

### \*\* CAUTION \*\*

WHEN DESIGNING OR LAYING OUT YOUR ACCESSORIES FOR THE VEHICLE, IT IS POSSIBLE TO OVERLOAD THE DASH HARNESS IF THE CURRENT DRAW OF ANY ACCESSORIES EXCEEDS THE PRINTED FUSE OR CIRCUIT BREAKER CAPACITY OF THE CAVITY. PLEASE CALL OUR TECHNICAL SUPPORT FOR HELP BEFORE ANY DEVIATION FROM THE RATED AMPERAGE CAPACITY OF THE FUSE OR CIRCUIT BREAKER CAVITY.

**M&H Electric Fabricators, Inc.**  
AUTOMOTIVE WIRING SYSTEMS

13537 Alondra Blvd. Santa Fe Springs, CA 90670  
Phone (562) 926-9552 Fax (562) 926-9572

INSTRUCTION SHEET  
ACCESSORY WIRE HARNESS

# TYPICAL WIRING INSTRUCTIONS FOR INSTALLING A SINGLE ELECTRIC RADIATOR FAN

## SCHEMATIC DIAGRAM 1

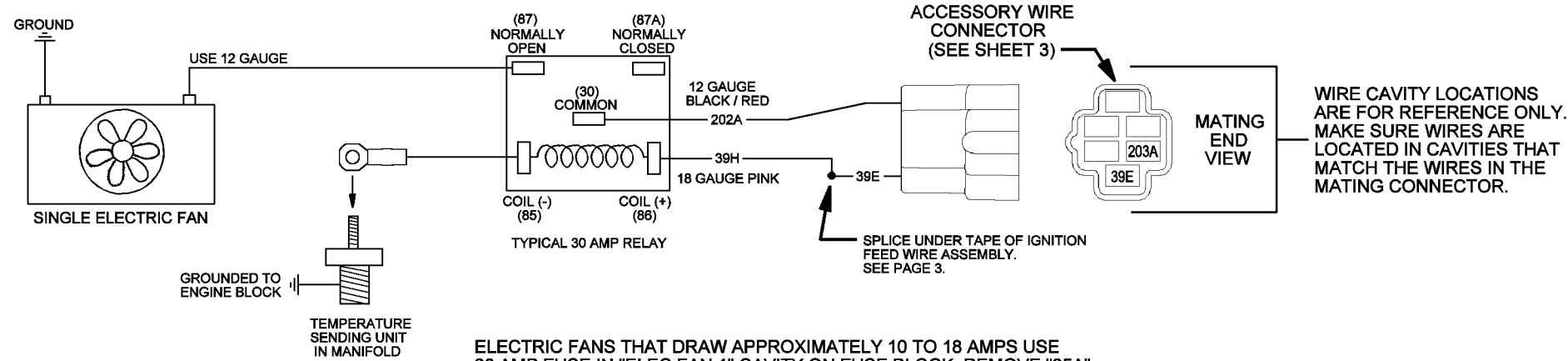

ELECTRIC FANS THAT DRAW APPROXIMATELY 10 TO 18 AMPS USE 20 AMP FUSE IN "ELEC FAN 1" CAVITY ON FUSE BLOCK. REMOVE "25A" FROM FUSE BLOCK USING ACETONE OR RAZOR BLADE. (SEE DETAIL 1)

ELECTRIC FANS THAT DRAW MORE THAN 18 AMPS USE 25 AMP FUSE IN "ELEC FAN 1" CAVITY ON FUSE BLOCK. REMOVE "20A" FROM FUSE BLOCK USING ACETONE OR RAZOR BLADE. (SEE DETAIL 1)

TYPICAL EXAMPLE OF SINGLE ELECTRIC FAN WIRING. RELAY ACTIVE WITH KEY IN RUN POSITION ONLY AND TEMPERATURE SENDER TRIGGERED.

DO NOT REMOVE ANY LETTERING UNTIL SYSTEM HAS BEEN FULLY TESTED

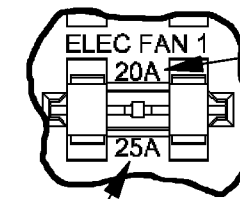

REMOVE 20A WHEN USING 25 AMP FUSE. REMOVE WITH RAZOR BLADE OR ACETONE.

REMOVE 25A WHEN USING 20 AMP FUSE. REMOVE WITH RAZOR BLADE OR ACETONE.

CAUTION: BE CAREFUL TO ONLY REMOVE INDICATED LETTERING WITHOUT REMOVING OTHER LETTERING. ACETONE WILL REMOVE ANY LETTERING THAT IT TOUCHES.

### DETAIL 1

SINGLE ELECTRIC FAN FUSE CAVITY

NOTE: RELAYS, RELAY CONNECTORS, SWITCHES PUMPS AND FANS ARE NOT PROVIDED WITH THIS KIT.

### WIRING INSTRUCTIONS FOR INSTALLING SINGLE ELECTRIC RADIATOR FAN

STEP 1: INSTALL SINGLE ELECTRIC FAN WIRING ACCORDING TO SCHEMATIC DIAGRAM 1.

STEP 2: DETERMINE THE AMPERAGE RATING OF YOUR ELECTRIC FAN AND CHOOSE THE APPROPRIATE FUSE FOR THE "ELEC FAN 1" CAVITY ON THE FUSEBLOCK.

STEP 3: FULLY TEST THE SYSTEM.

STEP 4: REMOVE APPROPRIATE LETTERING ON FUSEBLOCK. SEE DETAIL 1.

### WIRING INSTRUCTIONS FOR INSTALLING DUAL ELECTRIC RADIATOR FANS

STEP 1: INSTALL DUAL ELECTRIC FAN WIRING ACCORDING TO SCHEMATIC DIAGRAM 2.

STEP 2: DETERMINE THE AMPERAGE RATING OF YOUR ELECTRIC FANS AND CHOOSE THE APPROPRIATE FUSE FOR THE "ELEC FAN 1" & "ELEC FAN 2" CAVITIES ON THE FUSEBLOCK.

STEP 3: FULLY TEST THE SYSTEM.

STEP 4: REMOVE APPROPRIATE LETTERING ON FUSEBLOCK. SEE DETAIL 2.

**M&H Electric Fabricators, Inc.**  
 AUTOMOTIVE WIRING SYSTEMS  
 13537 Alondra Blvd. Santa Fe Springs, CA 90670  
 Phone (562) 926-9552 Fax (562) 926-9572

INSTRUCTION SHEET  
 ACCESSORY WIRING SCHEMATIC

# TYPICAL WIRING INSTRUCTIONS FOR INSTALLING DUAL ELECTRIC RADIATOR FANS.

## SCHEMATIC DIAGRAM 2

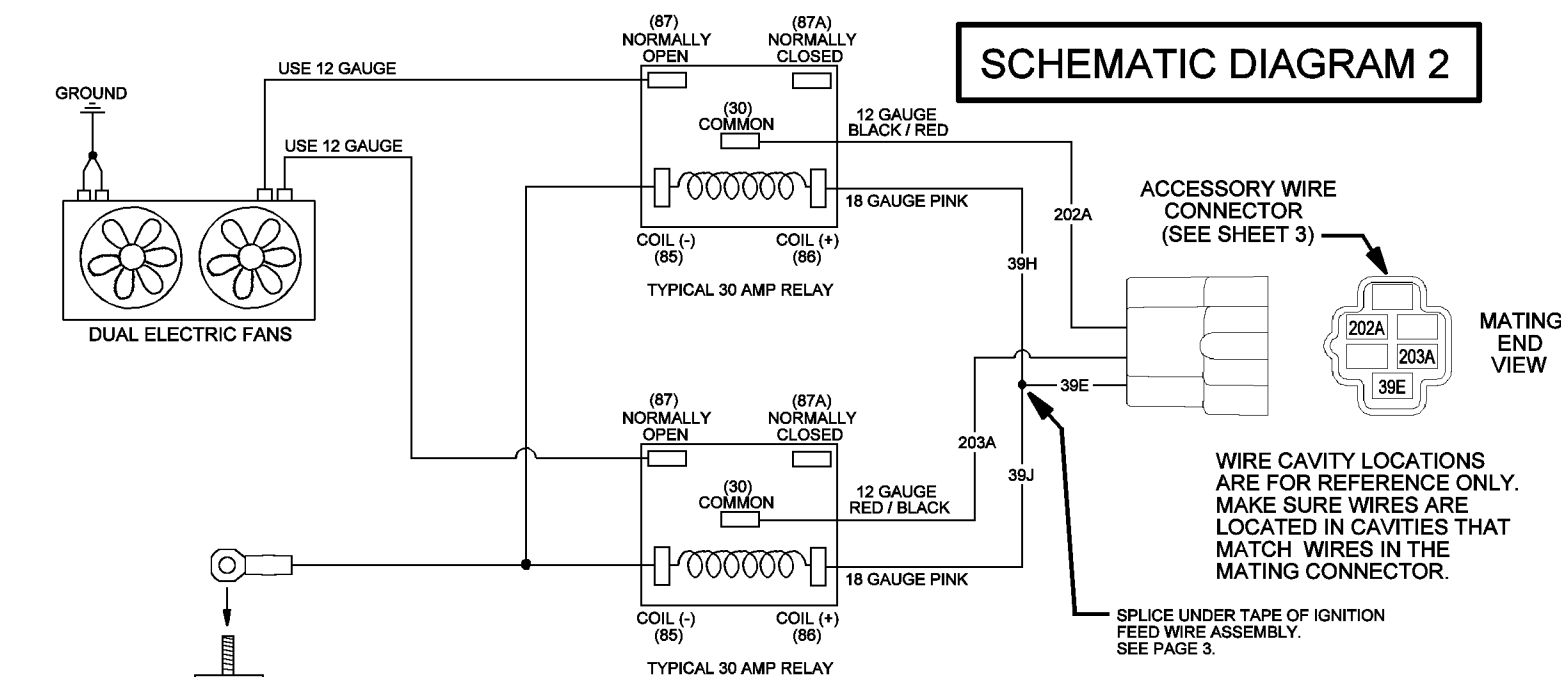

ELECTRIC FANS THAT DRAW APPROXIMATELY 10 TO 18 AMPS USE 20 AMP FUSE IN "ELEC FAN 1" CAVITY ON FUSE BLOCK. REMOVE "25A" FROM FUSE BLOCK USING ACETONE OR RAZOR BLADE. (SEE DETAIL 2)

ELECTRIC FANS THAT DRAW MORE THAN 18 AMPS USE 25 AMP FUSE IN "ELEC FAN 1" CAVITY ON FUSE BLOCK. REMOVE "20A" FROM FUSE BLOCK USING ACETONE OR RAZOR BLADE. (SEE DETAIL 2)

TYPICAL EXAMPLE OF DUAL ELECTRIC FAN WIRING. RELAY ACTIVE WITH KEY IN RUN POSITION ONLY AND TEMPERATURE SENDER TRIGGERED.

DO NOT REMOVE ANY LETTERING UNTIL SYSTEM HAS BEEN FULLY TESTED

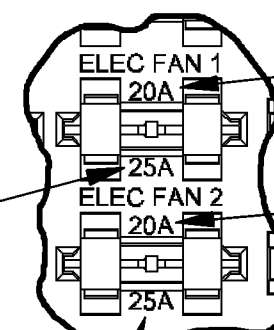

REMOVE 20A WHEN USING 25 AMP FUSE. REMOVE WITH RAZOR BLADE OR ACETONE.

REMOVE 20A WHEN USING 25 AMP FUSE. REMOVE WITH RAZOR BLADE OR ACETONE.

REMOVE 25A WHEN USING 20 AMP FUSE. REMOVE WITH RAZOR BLADE OR ACETONE.

REMOVE 25A WHEN USING 20 AMP FUSE. REMOVE WITH RAZOR BLADE OR ACETONE.

CAUTION: BE CAREFUL TO ONLY REMOVE INDICATED LETTERING WITHOUT REMOVING OTHER LETTERING. ACETONE WILL REMOVE ANY LETTERING THAT IT TOUCHES.

### DETAIL 2

DUAL ELECTRIC FANS FUSE CAVITIES

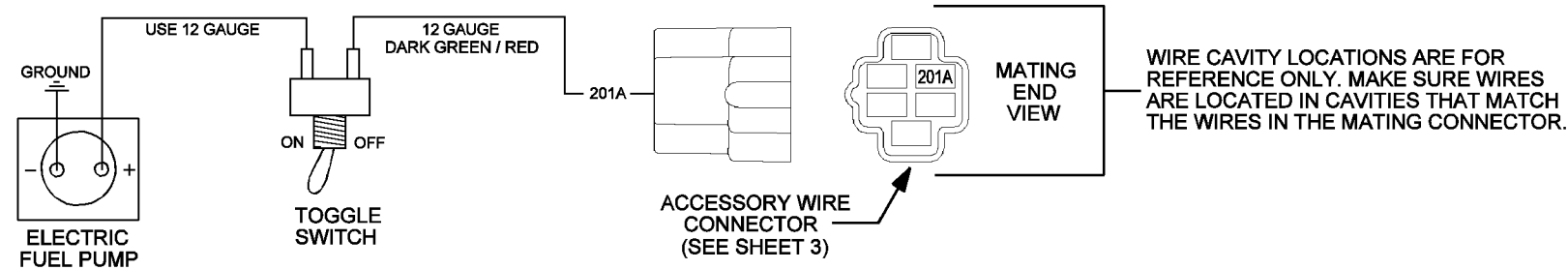

ELECTRIC FUEL PUMPS THAT DRAW APPROXIMATELY 10 TO 17 AMPS USE 20 AMP FUSE IN "ELEC FUEL PMP" CAVITY ON FUSE BLOCK. REMOVE "25A" FROM FUSE BLOCK USING ACETONE OR RAZOR BLADE. (SEE DETAIL 3)

ELECTRIC FUEL PUMPS THAT DRAW MORE THAN 17 AMPS USE 25A FUSE IN "ELEC FUEL PMP" CAVITY ON FUSE BLOCK. REMOVE "20A" FROM FUSE BLOCK USING ACETONE OR RAZOR BLADE. (SEE DETAIL 3)

**SCHEMATIC  
DIAGRAM  
3**

TYPICAL EXAMPLE OF FUEL PUMP WIRING WITHOUT RELAY.

**WIRING INSTRUCTIONS FOR INSTALLING  
ELECTRIC FUEL PUMP WITHOUT RELAY**

STEP 1:  
INSTALL ELECTRIC FUEL PUMP WIRING ACCORDING TO  
SCHEMATIC DIAGRAM 3.

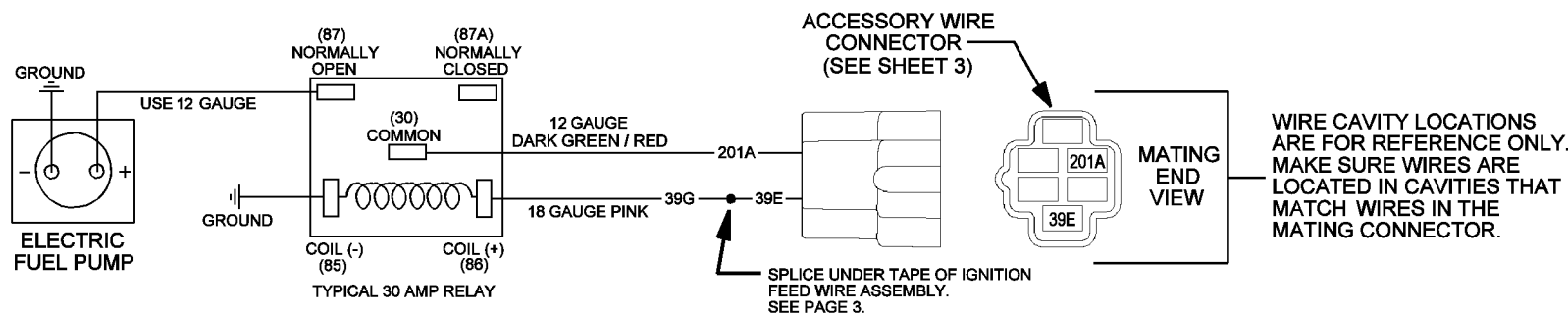

ELECTRIC FUEL PUMPS THAT DRAW APPROXIMATELY 10 TO 17 AMPS USE 20 AMP FUSE IN "ELEC FUEL PMP" CAVITY ON FUSE BLOCK. REMOVE "25A" FROM FUSE BLOCK USING ACETONE OR RAZOR BLADE. (SEE DETAIL 3)

ELECTRIC FUEL PUMPS THAT DRAW MORE THAN 17 AMPS USE 25A FUSE IN "ELEC FUEL PMP" CAVITY ON FUSE BLOCK. REMOVE "20A" FROM FUSE BLOCK USING ACETONE OR RAZOR BLADE. (SEE DETAIL 3)

TYPICAL EXAMPLE OF FUEL PUMP WIRING.  
RELAY ACTIVE WITH KEY IN RUN POSITION ONLY.

**SCHEMATIC  
DIAGRAM  
4**

**DO NOT REMOVE ANY LETTERING UNTIL  
SYSTEM HAS BEEN FULLY TESTED**

REMOVE 20A WHEN USING 25 AMP FUSE. REMOVE WITH RAZOR BLADE OR ACETONE.

REMOVE 25A WHEN USING 20 AMP FUSE. REMOVE WITH RAZOR BALDE OR ACETONE.

CAUTION: BE CAREFUL TO ONLY REMOVE INDICATED LETTERING WITHOUT REMOVING OTHER LETTERING. ACETONE WILL REMOVE ANY LETTERING THAT IT TOUCHES.

**DETAIL 3  
ELECTRIC FUEL PUMP FUSE CAVITY**

**WIRING INSTRUCTIONS FOR INSTALLING  
ELECTRIC FUEL PUMP WITH RELAY**

STEP 1:  
INSTALL ELECTRIC FUEL PUMP WIRING ACCORDING TO  
SCHEMATIC DIAGRAM 4.

STEP 2:  
DETERMINE THE AMPERAGE RATING OF YOUR ELECTRIC  
FUEL PUMP AND CHOOSE THE APPROPRIATE FUSE FOR THE  
"ELEC FUEL PMP" CAVITY ON THE FUSEBLOCK.  
SEE DETAIL 3.

STEP 3:  
FULLY TEST THE SYSTEM.

STEP 4:  
REMOVE APPROPRIATE LETTERING ON FUSEBLOCK.  
SEE DETAIL 3.

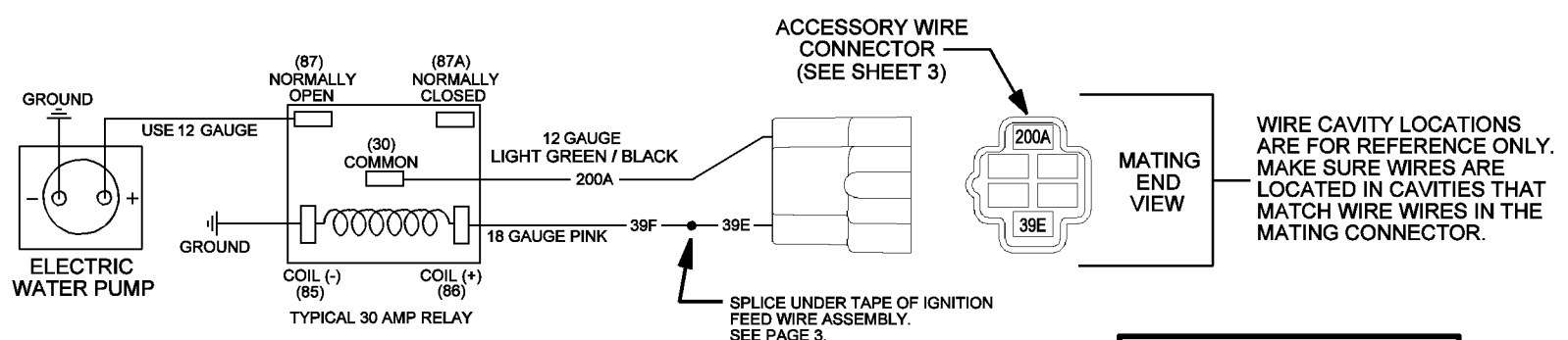

ELECTRIC WATER PUMPS THAT DRAW 13 AMPS OR LESS USE 15 AMP FUSE IN THE "ELEC WTR PMP" CAVITY ON THE FUSE BLOCK. REMOVE "20A" FROM FUSE BLOCK USING ACETONE OR RAZOR BLADE. (SEE DETAIL 4)

ELECTRIC WATER PUMPS THAT DRAW MORE THAN 13 AMPS USE 20 AMP FUSE IN THE "ELEC WTR PMP" CAVITY ON THE FUSE BLOCK. REMOVE "15A" FROM FUSE BLOCK USING ACETONE OR RAZOR BLADE. (SEE DETAIL 4)

TYPICAL EXAMPLE OF ELECTRIC WATER PUMP WIRING  
RELAY ACTIVE WITH KEY IN RUN POSITION.

**SCHEMATIC  
DIAGRAM  
5**

**DO NOT REMOVE ANY LETTERING UNTIL  
SYSTEM HAS BEEN FULLY TESTED**

REMOVE 15A WHEN USING 20 AMP FUSE. REMOVE WITH RAZOR BLADE OR ACETONE.

REMOVE 20A WHEN USING 15 AMP FUSE. REMOVE WITH RAZOR BLADE OR ACETONE.

CAUTION: BE CAREFUL TO ONLY REMOVE INDICATED LETTERING WITHOUT REMOVING OTHER LETTERING. ACETONE WILL REMOVE ANY LETTERING THAT IT TOUCHES.

**DETAIL 4  
ELECTRIC WATER PUMP FUSE CAVITY**

**WIRING INSTRUCTIONS FOR INSTALLING  
ELECTRIC WATER PUMP WITH RELAY**

STEP 1:  
INSTALL ELECTRIC WATER PUMP WIRING ACCORDING TO  
SCHEMATIC DIAGRAM 5.

STEP 2:  
DTERMINE THE AMPERAGE RATING OF YOUR ELECTRIC  
WATER PUMP AND CHOOSE THE APPROPRIATE FUSE FOR  
THE "ELEC WTR PMP" CAVITY ON THE FUSEBLOCK.  
SEE DETAIL 4.

STEP 3:  
FULLY TEST THE SYSTEM.

STEP 4:  
REMOVE APPROPRIATE LETTERING ON FUSEBLOCK.  
SEE DETAIL 4.



**INSTRUCTION SHEET  
ACCESSORY WIRING SCHEMATIC**

TO "CIG LTR"  
CAVITY ON  
FUSE BLOCK

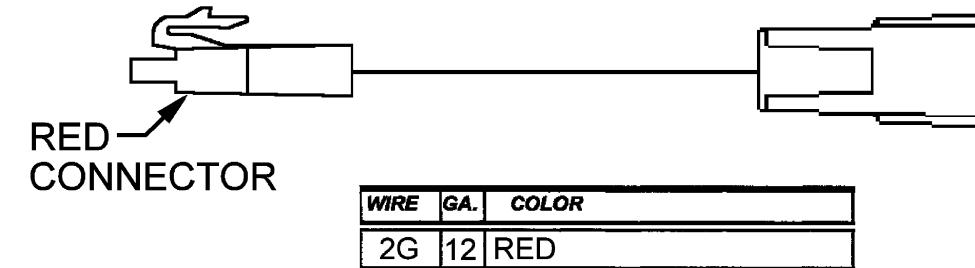

CIGARETTE  
LIGHTER  
1967-72 TRUCK

TO "IGN FUSED"  
CAVITY ON  
FUSEBLOCK

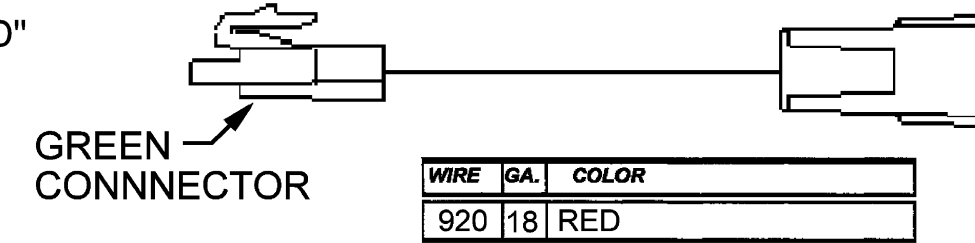

CRUISE CONTROL WIRING HARNESS  
1969-70 TRUCK

TO "IGN FUSED"  
CAVITY ON  
FUSE BLOCK

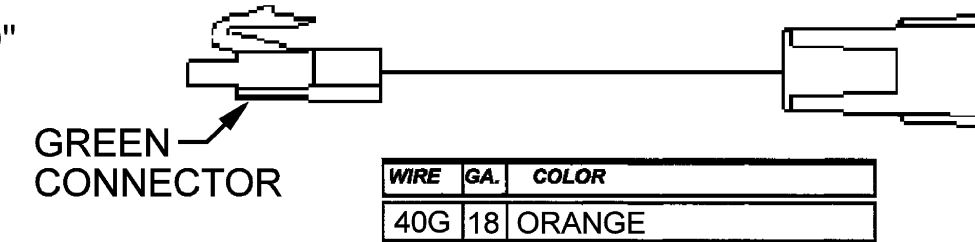

SPEED WARNING BUZZER HARNESS  
1967-72 TRUCK

TO "BAT FUSED"  
OR "GLV BOX"  
CAVITY ON  
FUSE BLOCK

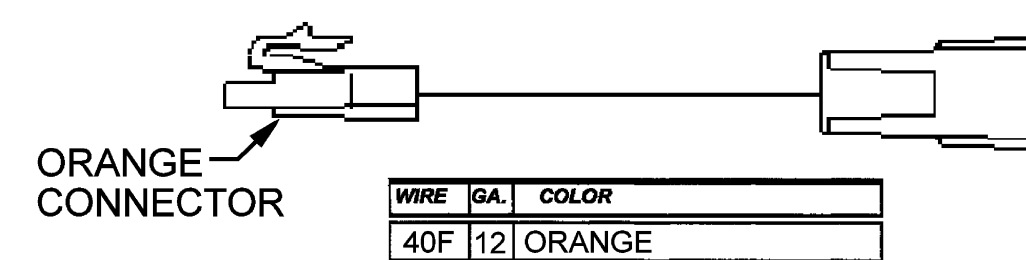

AIR CONDITIONING HARNESS  
1967-72 TRUCK  
GLOVE BOX LAMP HARNESS  
1967-72 TRUCK

3 INCLUDED

TO "IGN UNFUSED"  
CAVITY ON  
FUSE BLOCK

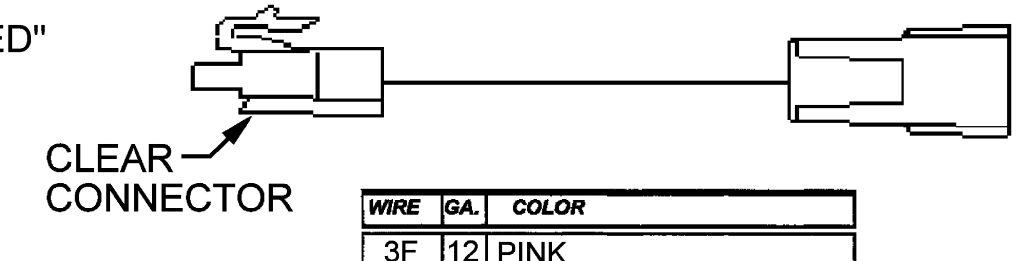

TACH HARNESS  
1967-72 TRUCK  
TRANSMISSION KICKDOWN HARNESS  
1967-72  
TRANSMISSION CONTROLLED SPARK (TCS) HARNESS  
1970 & 1972 TRUCK  
AIR CONDITIONING HARNESS  
1971-72 TRUCK

2 INCLUDED

TO "INST PNL LPS 1"  
OR "INST PNL LPS 2"  
CAVITY ON FUSE BLOCK

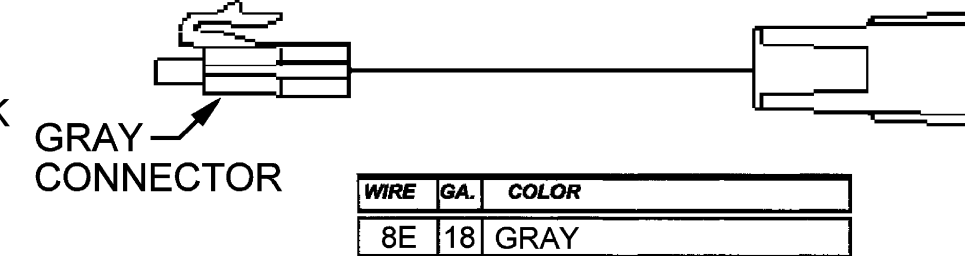

AIR CONDITIONING HARNESS  
1969-72 TRUCK

TO "RADIO"  
CAVITY ON  
FUSE BLOCK

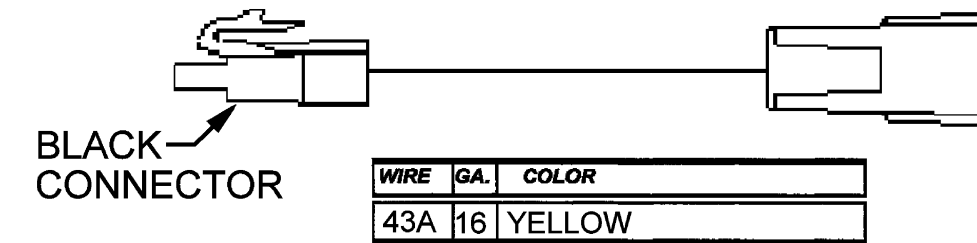

RADIO POWER WIRE  
1967-72 TRUCK

# ACCESSORY ADAPTER WIRES

USE THIS CONNECTOR FOR OTHER FACTORY ACCESSORIES THAT REQUIRE THE SAME CAVITY ON THE FUSEBLOCK WITH FACTORY TYPE ACCESSORIES. THE FINAL TERMINATING ACCESSORY WILL NOT HAVE THIS ACCESSORY CONTINUATION JUMPER.

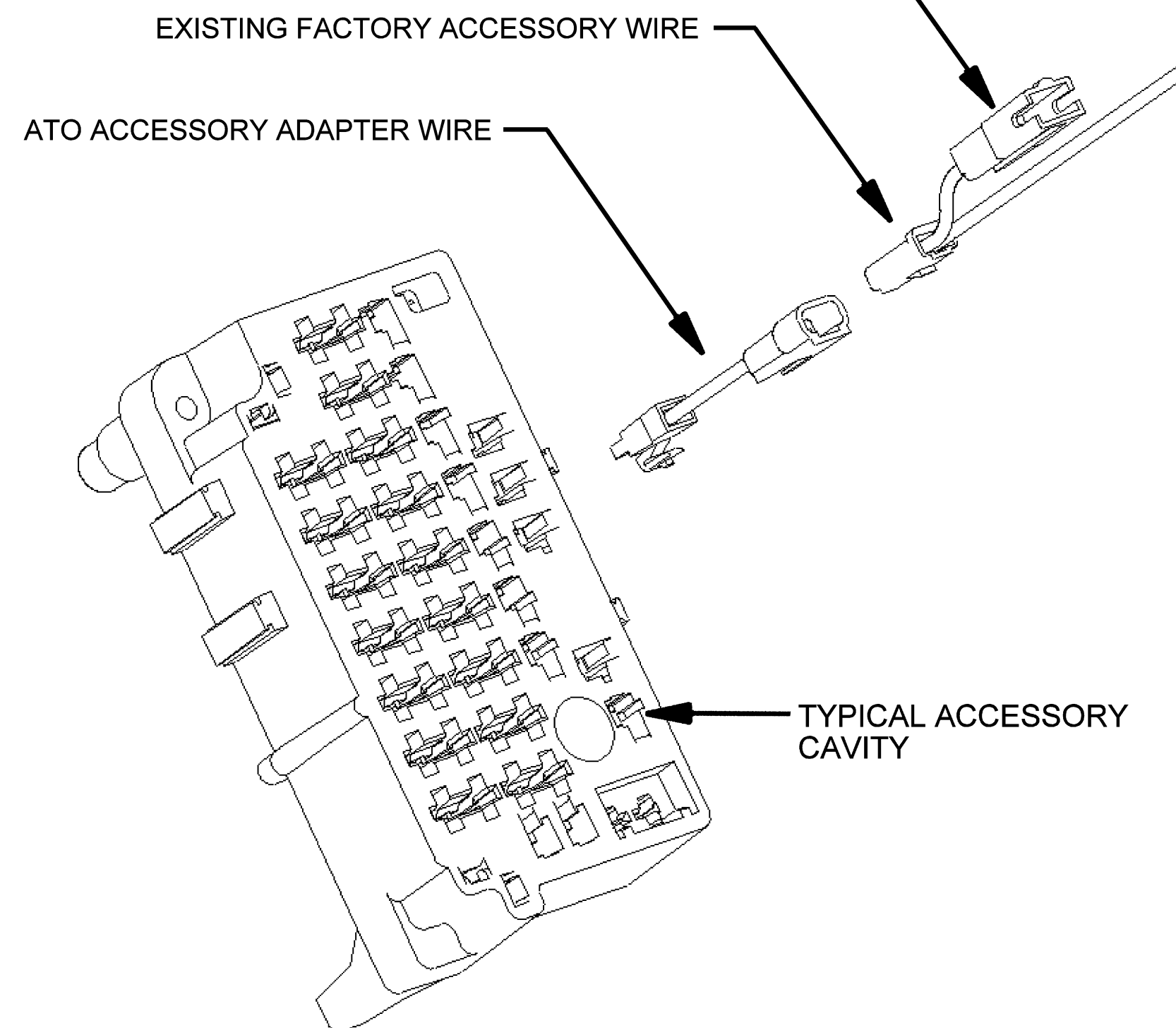

**M&H Electric Fabricators, Inc.**  
 AUTOMOTIVE WIRING SYSTEMS  
 13537 Alondra Blvd. Santa Fe Springs, CA 90670  
 Phone (562) 926-9552 Fax (562) 926-9572

INSTRUCTION SHEET  
ACCESSORY ADAPTER WIRES

THIS LOOSE PIECE CONNECTOR AND TERMINAL IS PROVIDED FOR "PWR ACC 1" OUTPUT CAVITY ON FRONT OF FUSEBLOCK. TERMINAL MUST BE HAND CRIMPED & SOLDERED TO WIRE.

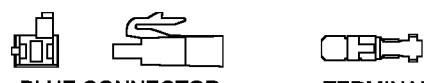

BLUE CONNECTOR      TERMINAL

THIS CAVITY IS DEDICATED FOR A SECOND POWER ACCESSORY OPTION WHEN THE CIRCUIT BREAKER CAVITY IS USED OR FOR A SMALLER POWER ACCESSORY OPTION AS THIS CAVITY IS RATED AT EITHER 20 OR 30 AMPS. IT CAN BE USED FOR POWER ACCESSORY OPTIONS SUCH AS POWER SEATS, POWER WINDOWS, POWER LOCKS AND OTHER ACCESSORIES. SEE DETAIL 2.

CAUTION: DO NOT INSERT FUSE IN "PWR ACC 1" CAVITY IF THIS OPTION IS NOT USED.

NOTE: SEE DETAIL 1 IF ONLY A SINGLE POWER ACCESSORY OPTION WILL BE USED OR FOR LARGER AMPERAGE REQUIREMENTS FROM 30 TO 40 AMPS.

**DO NOT REMOVE ANY LETTERING UNTIL SYSTEM HAS BEEN FULLY TESTED**

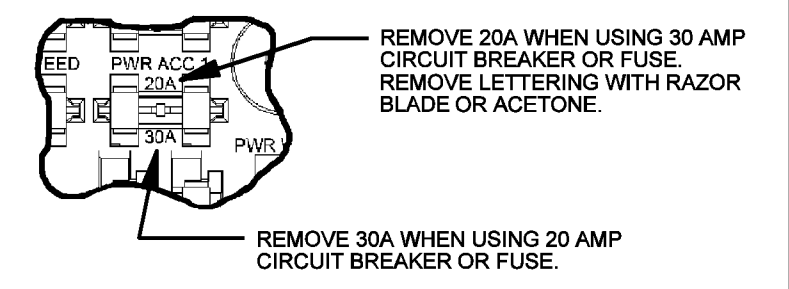

CAUTION: BE CAREFUL TO ONLY REMOVE INDICATED LETTERING WITHOUT REMOVING OTHER LETTERING. ACETONE WILL REMOVE ANY LETTERING THAT IT TOUCHES.

**DETAIL 2**  
POWER ACCESSORY FUSE CAVITY

**DO NOT REMOVE ANY LETTERING UNTIL SYSTEM HAS BEEN FULLY TESTED**

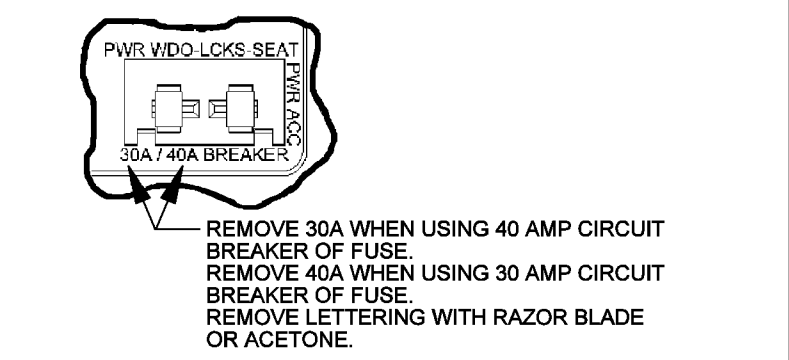

CAUTION: BE CAREFUL TO ONLY REMOVE INDICATED LETTERING WITHOUT REMOVING OTHER LETTERING. ACETONE WILL REMOVE ANY LETTERING THAT IT TOUCHES.

**DETAIL 1**  
POWER ACCESSORY CIRCUIT BREAKER CAVITY

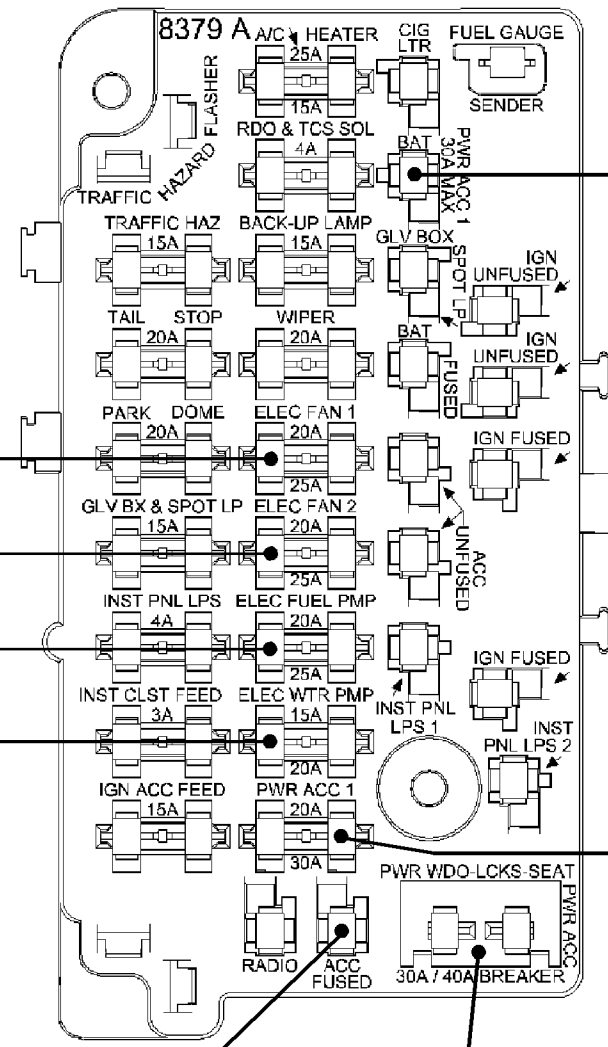

THIS IS A DEDICATED CAVITY FOR A SINGLE ELECTRIC RADIATOR FAN OR OTHER ACCESSORY. SEE PAGES 3 & 4 CIRCUIT 39H.  
CAUTION: DO NOT INSERT FUSE IN CAVITY IF THIS OPTION IS NOT USED.

THIS IS A DEDICATED CAVITY FOR A SECOND RADIATOR FAN OR OTHER ACCESSORY. SEE PAGES 3 & 4 CIRCUIT 39J.  
CAUTION: DO NOT INSERT FUSE IN CAVITY IF THIS OPTION IS NOT USED.

THIS IS A DEDICATED CAVITY FOR AN ELECTRIC FUEL PUMP OR OTHER ACCESSORY. SEE PAGES 3 & 5 CIRCUIT 39G.  
CAUTION: DO NOT INSERT FUSE IN CAVITY IF THIS OPTION IS NOT USED.

THIS IS A DEDICATED CAVITY FOR AN ELECTRIC WATER PUMP DRIVE OR OTHER ACCESSORY. SEE PAGES 3 & 5 CIRCUIT 39F.  
CAUTION: DO NOT INSERT FUSE IN CAVITY IF THIS OPTION IS NOT USED.

14 ACCESSORY CAVITIES TO ACCOMODATE EXISTING ACCESSORIES AS WELL AS NEW ACCESSORY OPTIONS SEE PAGE 6.

THIS IS A DEDICATED CAVITY FOR A SINGLE POWER ACCESSORY OPTION SUCH AS POWER WINDOWS, POWER LOCKS, POWER SEATS OR OTHER ACCESSORIES. THIS CAVITY IS DESIGNED FOR A CIRCUIT BREAKER BUT A FUSE MAY BE USED. ALWAYS ORGANIZE THE LARGEST AMPERAGE DRAW POWER ACCESSORY OPTION ON THIS CAVITY. SEE DETAIL 1.

CAUTION: DO NOT INSERT CIRCUIT BREAKER OR FUSE IF THIS OPTION IS NOT USED.

NOTE: IF A SECOND POWER ACCESSORY OPTION IS USED THEN USE THE "PWR ACC 1" CAVITY.

# GENERAL NOTES & GUIDELINES

## FUSEBLOCK CIRCUIT LAYOUT

USED FOR DIAGNOSTIC PURPOSES  
SEE PAGE 1

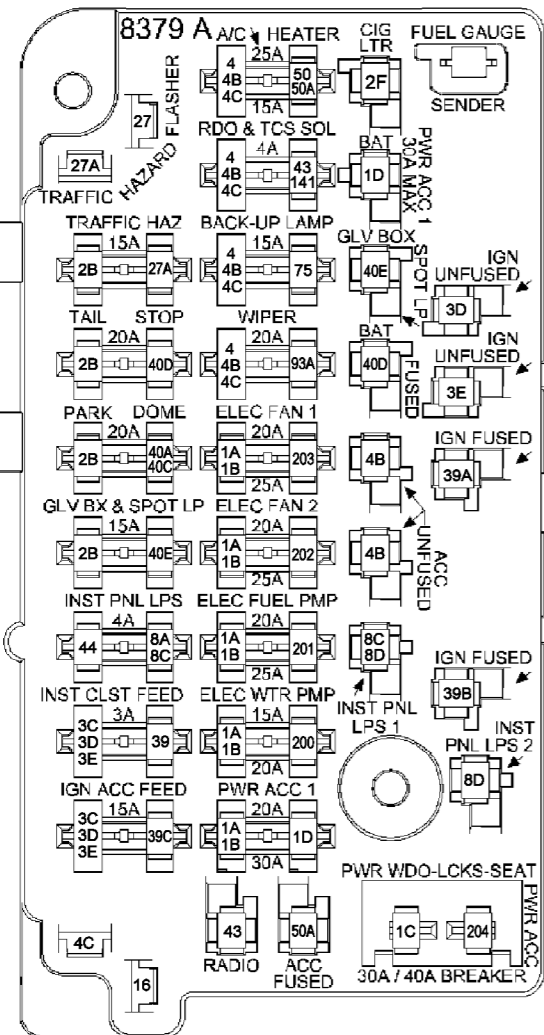

USED FOR 1 OR 2  
M&H ELECTRIC  
RELAY KITS.  
SOME TRUCK  
MODELS DO NOT  
HAVE SUFFICIENT  
SIDE CLEARANCE  
FOR THIS OPTION.  
RELAY KIT PART  
NUMBER 41356.

USED FOR IN-LINE  
CONNECTOR KIT,  
SPARE FUSE HOLDER  
OR SPARE ATO/ATC  
FUSEBLOCK KIT.  
SOME TRUCK  
MODELS DO NOT  
HAVE SUFFICIENT  
SIDE CLEARANCE  
FOR THIS OPTION.  
  
IN-LINE CONNECTOR KIT  
PART NUMBER 41355.  
  
SPARE FUSE HOLDER  
PART NUMBER 41357.  
  
SPARE ATO/ATC  
FUSEBLOCK KIT  
PART NUMBER 41359.

1. POWER WINDOWS, LOCKS & SEAT CAVITIES AS WELL AS THE PWR ACC 1 CAVITY ARE DESIGNED FOR LARGER POWER ACCESSORIES. YOU CAN USE THESE CAVITIES AS WELL AS ALL THE EXTRA CAVITIES FOR FANS, FUEL PUMPS AND ELECTRIC WATER PUMPS FOR ANY ACCESSORY YOU PREFER. WE HAVE INSTALLED THE MOST PREDOMINATE ONES HERE.
2. IN EVERY CASE A CIRCUIT BREAKER OF THE ATO/ATC TYPE CAN BE USED IN PLACE OF THE PLASTIC FUSES. THEY ARE COMMONLY AVAILABE IN THE AFTERMARKET OR YOUR LOCAL AUTO PARTS STORE.
3. THE FOLLOWING ACCESSORY KITS ARE AVAILABLE FOR YOUR CLASSIC AUTO FUSE SERIES DASH HARNESS:

- 40356 - FUSE, FLASHER & CIRCUIT BREAKER KIT.  
1967-72 TRUCKS  
INCLUDES:  
FILL ALL FUSES WITH SPARES, ONE 30 AMP CIRCUIT BREAKER AND ONE 40 AMP CIRCUIT BREAKER. SEE PAGE 9.
- 41356 - RELAY & CONNECTOR KIT  
ALL MODELS  
30 AMP RELAY, CONNECTOR & TERMINAL KITS ALLOW YOU TO CLEANLY ROUTE WIRES AND TERMINATE AT RELAY CONNECTORS. NO SPLICING OF PIGTAILS. THESE CAN ALSO BE CONNECTED TO THE RIBS ON THE SIDE OF THE FUSEBLOCK IF SUFFICIENT CLEARANCE IS AVAILABLE, ONLY CERTAIN YEARS HAVE ENOUGH SPACE ON SIDE OF FUSEBLOCK. SEE PAGE 9.
- 41358 - FRONT OF FUSEBLOCK ACCESSORY CONNECTOR & TERMINALS KIT.  
1967-78 TRUCKS  
INCLUDES ALL CONNECTORS NECESSARY TO FILL ALL CAVITIES IN FRONT OF FUSEBLOCK & CORRECT TERMINALS WITH SPARES. NO WIRE IS PROVIDED IN THIS KIT. TERMINALS MUST BE HAND CRIMPED AND SOLDERED TO WIRE. SEE PAGE 9.
- 41355 - 11-WAY CONNECTOR KIT FOR ATO/ATC SERIES FUSEBLOCK.  
ALL MODELS.  
FOR MOUNTED INLINE CAPABILITY. THIS MAY NOT FIT CERTAIN YEARS BECAUSE OF SIDE CLEARANCES ON FUSEBLOCKS. SEE PAGE 9.
- 41357 - SPARE FUSE HOLDER FOR ATO/ATC SERIES FUSEBLOCKS.  
ALL MODELS.  
NOTE: SOME TRUCK MODELS MAY NOT HAVE SUFFICIENT CLEARANCE FOR THIS OPTION TO ATTACH TO FUSEBLOCK. SEE PAGE 9.
- 41359 - ATO/ATC 6-WAY SPARE ACCESSORY FUSEBLOCK KIT.  
NOTE: SOME TRUCK MODELS MAY NOT HAVE SUFFICIENT CLEARANCE FOR THIS OPTION. IT CAN ALSO BE MOUNTED AS A STAND ALONE FUSEBLOCK WITH 6 EXTRA FUSES.

4. SOME INSTALLATION GUIDELINES & CAUTIONS:
  - A - USE MINIMUM 4 GAUGE BATTERY CABLES OR LARGER IF YOU INTEND ON USING ANY OF THE POWER ACCESSORIES. THE LARGER THE BETTER.
  - B - USE CAUTION WHEN ADDING LARGE AMPLIFIERS BIGGER THAN 100 WATTS OR LIKE/KIND ACCESSORIES AS THESE TYPES OF ACCESSORIES SHOULD BE CONNECTED DIRECTLY TO THE BATTERY NOT TO YOUR NEW DASH HARNESS. CALL OUR TECHNICAL SUPPORT LINE FOR HELP IF NEEDED.
  - C - BY FAR THE MOST PREDOMINANT TECH SUPPORT ISSUE IS DEVICES ACTING UP IN THE INSTRUMENT CLUSTER SUCH AS FUEL GAUGES PEGGING TO FULL WHEN TANK IS EMPTY, ETC. THE FIRST RULE WHEN ANY SUCH COMPONENT IN THE INSTRUMENT CLUSTER IS NOT WORKING CORRECTLY IS THAT IT HAS A BAD GROUND. THE 150 CIRCUIT MUST BE WELL GROUNDED VIA THE METAL CLIP ON THE END OF THE WIRE NEAR THE IGNITION SWITCH WIRES. CLEAN SHEET METAL BEFORE PRESSING CLIP ON THE EDGE BY THE RADIO MOUNTING STRUCTURE UNDER DASH OR INSTALL A SEPARATE GROUND WIRE FROM INSTRUMENT CLUSTER TO A GOOD GROUND. ALWAYS REMEMBER THE MORE GOUNDS THE BETTER PERFORMANCE FROM YOUR WIRING SYSTEMS.
  - D - ANY QUESTIONS CALL OUR TECH SUPPORT LINE AT (562) 926-9552.



**M&H Electric Fabricators, Inc.**  
AUTOMOTIVE WIRING SYSTEMS  
13537 Alondra Blvd. Santa Fe Springs, CA 90670  
Phone (562) 926-9552 Fax (562) 926-9572

**INSTRUCTION SHEET  
GENERAL NOTES & GUIDELINES**

PAGE 8 OF 9
92971043
SIZE  
B



**40355**  
**FUSE & FLASHER KIT**  
 1967-72 TRUCKS

- (2) - FLASHER 552
- (7) - ATO 15 AMP FUSE
- (9) - ATO 20 AMP FUSE
- (3) - ATO 4 AMP FUSE
- (2) - ATO 3 AMP FUSE
- (5) - ATO 25 AMP FUSE
- (2) - ATO 30 AMP FUSE
- (1) - ATO TYPE 30 AMP CIRCUIT BREAKER
- (1) - ATO TYPE 40 AMP CIRCUIT BREAKER

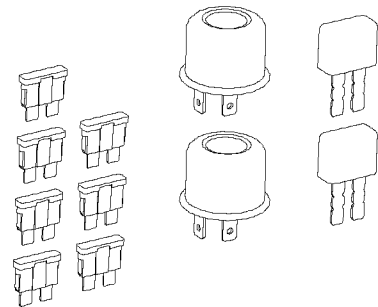

**41355**  
**11-WAY CONNECTOR KIT**  
 ALL MODELS

- (1) - 11-WAY FEMALE CONNECTOR
- (1) - 11-WAY MALE CONNECTOR
- (11) - 14/16 GAUGE FEMALE TERMINAL
- (11) - 10/12 GAUGE FEMALE TERMINAL
- (2) - 14/16 GAUGE MALE TERMINAL
- (2) - 10/12 GAUGE MALE TERMINAL

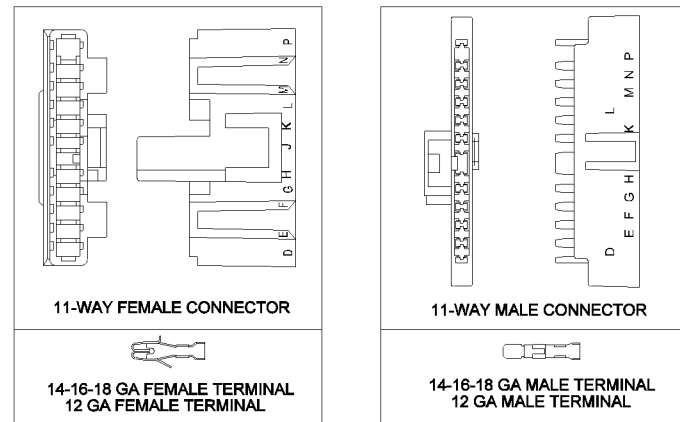

**41358**  
**FRONT OF FUSEBLOCK**  
**ACCESSORY CONNECTOR**  
**& TERMINALS KIT**  
 1967-78 TRUCKS

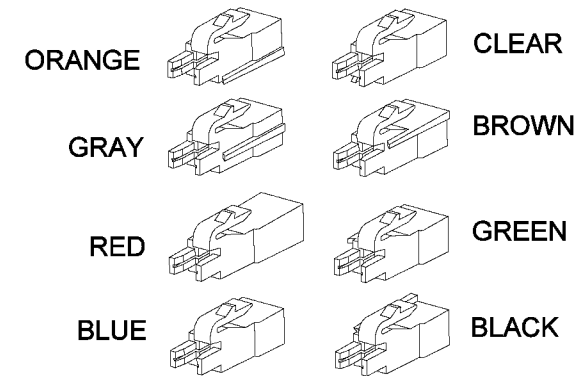

14-16-18 GA MALE TERMINAL  
 12-10 GA MALE TERMINAL

**41359**  
**6-WAY ACCESSORY**  
**FUSEBLOCK KIT**

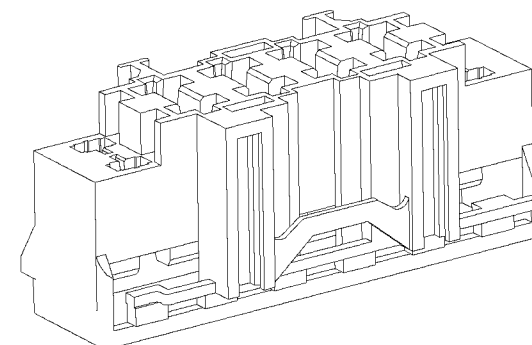

6-WAY ACCESSORY FUSEBLOCK

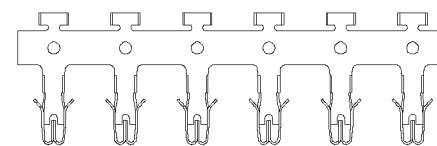

14-16-18 GA TERMINAL BUS BAR  
 12-10 GA TERMINAL BUS BAR

**(COMING SOON)**  
**SPARE FUSE HOLDER**  
 ALL MODELS

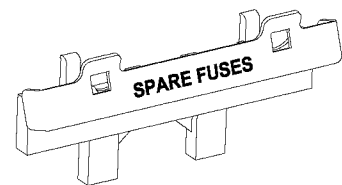

**41356**  
**RELAY & CONNECTOR KIT**  
 ALL MODELS

- (1) - 12033871 5-WAY RELAY CONNECTOR
- (1) - SECONDARY LOCK FOR RELAY CONNECTOR
- (1) - RELAY
- (3) 14-16-18 GA FEMALE TERMINAL
- (2) 10-12 GA FEMALE TERMINAL

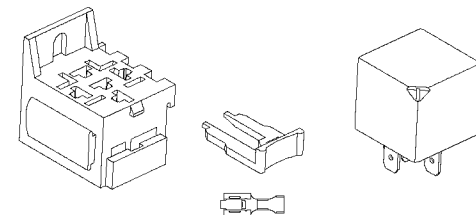

SEE PAGE 7 FOR THE FOLLOWING  
 FUSE BLOCK KIT APPLICATIONS:

40355  
 41358

SEE PAGE 8 FOR THE FOLLOWING  
 FUSE BLOCK KIT APPLICATIONS:

41355  
 41356  
 41359  
 SPARE FUSE HOLDER (COMING SOON)

**M&H Electric Fabricators, Inc.**  
 AUTOMOTIVE WIRING SYSTEMS  
 13537 Alondra Blvd. Santa Fe Springs, CA 90670  
 Phone (562) 926-9552 Fax (562) 926-9572

INSTRUCTION SHEET  
 AVAILABLE KITS