

D

DISTRIBUTABLE

THIS DRAWING AND DESIGN HEREON
CONSTITUTES A PROPRIETARY DESIGN
OF M&H ELECTRIC FABRICATORS, INC.
AND IS NOT TO BE DUPLICATED OR
REPRODUCED WITHOUT AUTHORITY OF
M&H ELECTRIC FABRICATORS, INC.

REVISIONS

DATE	REV.	DESCRIPTION	APPR. BY
02-01-2017	A	RELEASED FOR PRODUCTION	400

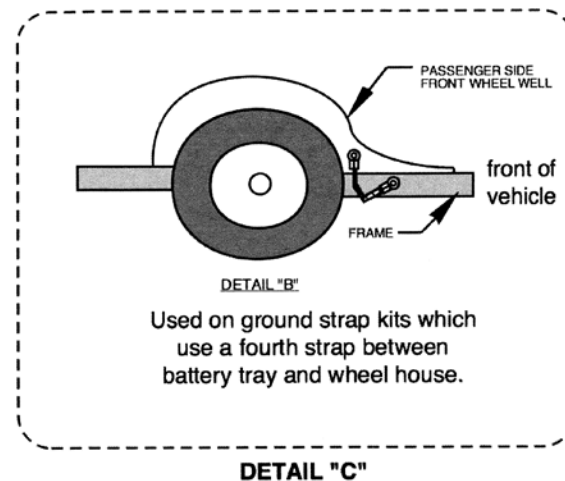
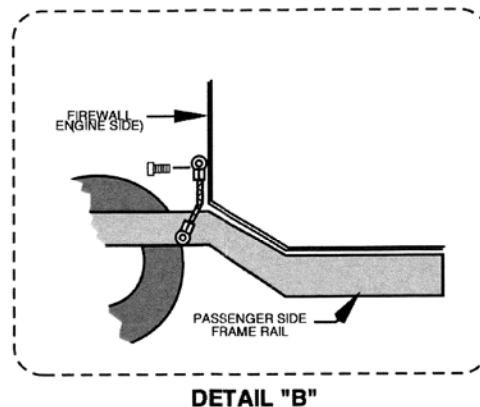
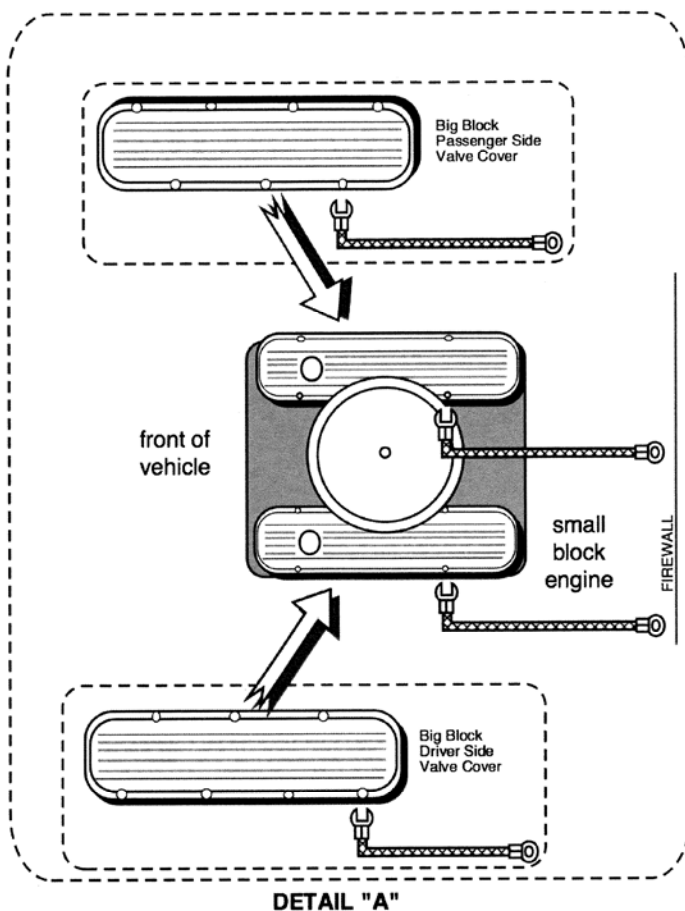
**Installation Instructions:****Small Block V-8:**

- 1 Bolt one end of the shortest ground strap to the passenger side frame rail. The other end will be bolted to the firewall on the passenger side as shown in detail "B".
- 2 If your kit includes four straps, the next longer strap will bolt from the frame rail to the passenger side wheel house beneath the battery tray area, as shown in detail "C".
3. The other two ground straps are for the valve covers. Bolt the ring terminal ends to firewall. Bolt the open-ended terminals to the valve cover as shown in detail "A".

Big Block V-8:

1. Bolt one end of the shortest ground strap to the passenger side frame rail. The other end will be bolted to the firewall on the passenger side, as shown in detail "B".
2. If your kit includes four straps, the next longer strap will bolt from the frame rail to the passenger side wheel house beneath the battery tray area, as shown in detail "C".
3. The LONGER of the two remaining straps is for the passenger side valve cover. Bolt the ring terminal end to firewall, the open-ended terminal to the valve cover as shown in detail "A".
4. The SHORTER of the valve cover straps is for the driver side valve cover. Bolt the ring terminal end to firewall, the open-ended terminal to the valve cover as shown in detail "A".

M&H ELECTRIC FABRICATORS, INC.
AUTOMOTIVE WIRING SYSTEMS
(562) 926-9552 www.wiringharness.com

DATE: 10/17/13	REFERENCE NO. 27440	SHEET NO. 1 OF 1
-------------------	------------------------	---------------------

TITLE

INSTRUCTIONS SHEET FOR
CHEVELLE '67 - '69, 8 CYL.
GROUND STRAP KIT

PART NO.

92964800