

M&H ELECTRIC FABRICATORS, INC.

AUTOMOTIVE WIRING SYSTEMS

The design and documents included in this assembly are the exclusive property of M&H Electric Fabricators, Inc. No part of the kit design or documentation may be reproduced without the express permission of M&H Electric Fabricators, Inc.

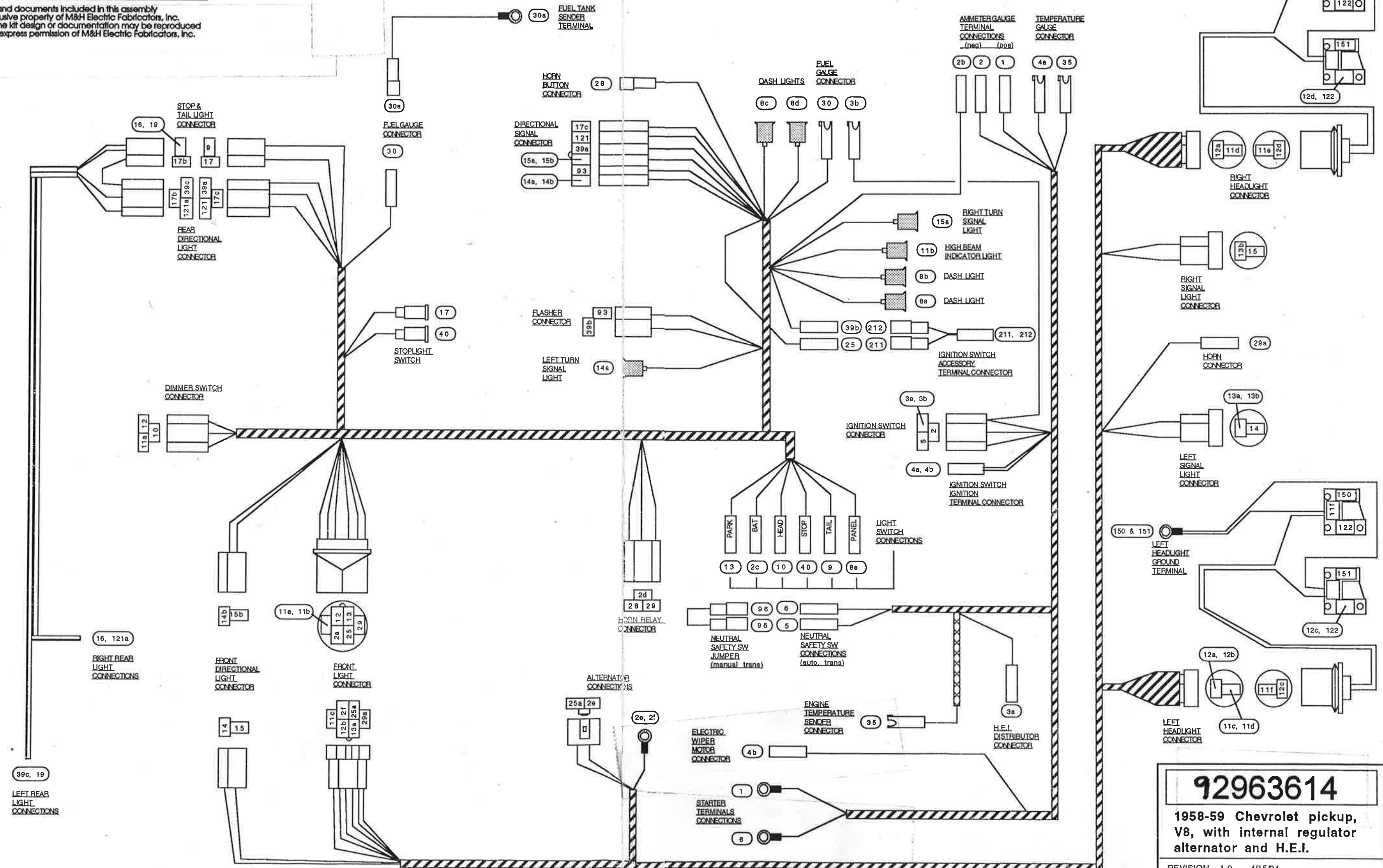

92963614
 1958-59 Chevrolet pickup,
 V8, with internal regulator
 alternator and H.E.I.
 REVISION 1.0 4/15/84
 REFERENCE 2963614

WIRE USAGE CHART INSTRUCTION SHEET

92963614

WIRE #	WIRE COLOR	GAUGE	CIRCUIT DESCRIPTION
1	black	12	Starter motor "BAT" terminal to ammeter "+" terminal
2	red	12	"Batt" on ignition switch to ammeter (-) terminal
2 a	red	10	Front light connector to in line splice
2 b	red	10	In line splice to ammeter gauge "-" terminal
2 c	red	12	In line splice to light switch "BAT" terminal
2 d	red	14	Horn relay "BAT" terminal to in line splice
2 e	red	10	Internal regulator alternator connector to alternator "BAT" terminal
2 f	red	18	Alternator "BAT" terminal to front light connector
3 a	pink	12	Ignition switch "IGN" terminal to H.E.I. connection on distributor
3 b	pink	18	Ignition switch "IGN" terminal to fuel gauge "IGN" terminal
4 a	pink	18	Ignition switch "IGN" terminal to "IGN" on temperature gauge
4 b	brown	18	Ignition switch "IGN" terminal to electric wiper motor
5	purple	14	Neutral safety switch to ignition switch "SOL" terminal
6	purple	14	Starter motor "SWITCH" terminal to neutral safety switch
8 a	gray	18	In line splice to instrument panel light
8 b	gray	18	In line splice to instrument panel light
8 c	gray	18	In line splice to instrument panel light
8 d	gray	18	In line splice to instrument panel light
8 e	gray	18	In line splice to light switch "PANEL LIGHT" terminal
9	black	18	Stop & tail light connector to light switch "TAIL" terminal
10	lt blue	18	Dimmer switch "BAT" terminal to light switch "HEADLIGHT" terminal
11 a	lt green	18	Front light connector to dimmer switch "HIGH BEAM" terminal
11 b	lt green	18	Front light connector to high beam indicator light
11 c	lt green	16	Front light connector to left headlamp high beam connection
11 d	lt green	16	Right headlamp high beam connection to left headlamp high beam connection
11 e	lt green	16	Right headlight connector to right headlight (high beam)
11 f	lt green	16	Left headlight connector to left headlight (high beam)
12	tan	18	Front light connector to dimmer switch "LOW BEAM" terminal
12 a	tan	18	Right headlamp low beam connection to left headlamp low beam connection
12 b	tan	18	Front light connector to left headlamp low beam connection
12 c	tan	16	Left headlight connector to left headlight (low beam)
12 d	tan	16	Right headlight connector to right headlight (low beam)
13	purple	18	Front light connector to light switch "PARK" terminal
13 a	purple	18	Front light connector to left parking light connector
13 b	purple	18	Right parking light connector to left parking light connector
14	lt blue	18	Front directional light connector to left signal light connector
14 a	lt blue	18	Directional signal connector to left turn signal light
14 b	lt blue	18	Directional signal connector to front directional light connector
15	dk blue	18	Front directional light connector to right signal light connector
15 a	dk blue	18	Directional signal connector to right turn signal light
15 b	dk blue	18	Directional signal connector to front directional light connector

WIRE USAGE CHART INSTRUCTION SHEET

92963614

WIRE #	WIRE COLOR	GAUGE	CIRCUIT DESCRIPTION
16	dk green	16	Stop & tail light connector to right rear tail light connection
17	white	18	Stop & tail light connector to stop light switch
17 b	lt green	16	Stop & tail light connector to rear directional light connector
17 c	white	18	Directional signal connector to rear directional light connector
19	yellow	16	Stop & tail light connector to left rear tail light connection
25	brown	18	Front light connector to ignition switch "ACC" terminal
25 a	brown	12	Internal regulator alternator connector to front light connector
28	tan	18	Horn button connector to horn relay "S" terminal
29	black	14	Front light connector to horn relay "H" terminal
29 a	black	14	Front light connector to horn connector
30	brown	18	Fuel gauge connector to gas gauge
30 a	brown	18	Fuel gauge connector to gas tank sending unit
35	dk green	18	Temperature gauge sending unit to temperature gauge "SENDER" terminal
39 a	pink	18	Directional signal connector to rear directional light connector
39 b	pink	18	Ignition switch accessory terminal to flasher connector
39 c	brown	16	Rear directional light connector to left rear directional light connection
40	orange	18	Stop light switch to light switch "STOP" terminal
93	yellow	18	Directional signal connector to flasher connector
96	purple	14	Neutral safety switch jumper
121	purple	18	Directional signal connector to rear directional light connector
121 a	lt green	16	Rear directional light connector to right rear directional light connection
122	white	16	Headlight high beam jumper wire
122	white	16	Headlight high beam jumper wire
150	black	16	Right headlight ground wire
150	black	16	Left headlight ground wire
151	black	16	Right headlight ground wire
151	black	16	Left headlight ground wire
211	tan	18	Ignition switch "Acc" terminal jumper connection
212	pink	14	Ignition switch "Acc" terminal jumper connection