

THIS DRAWING AND DESIGN HEREON
CONSTITUTES A PROPRIETARY DESIGN
OF M&H ELECTRIC FABRICATORS, INC.
AND IS NOT TO BE DUPLICATED OR
REPRODUCED WITHOUT AUTHORITY OF
M&H ELECTRIC FABRICATORS, INC.

DO NOT SCALE

D

C

B

A

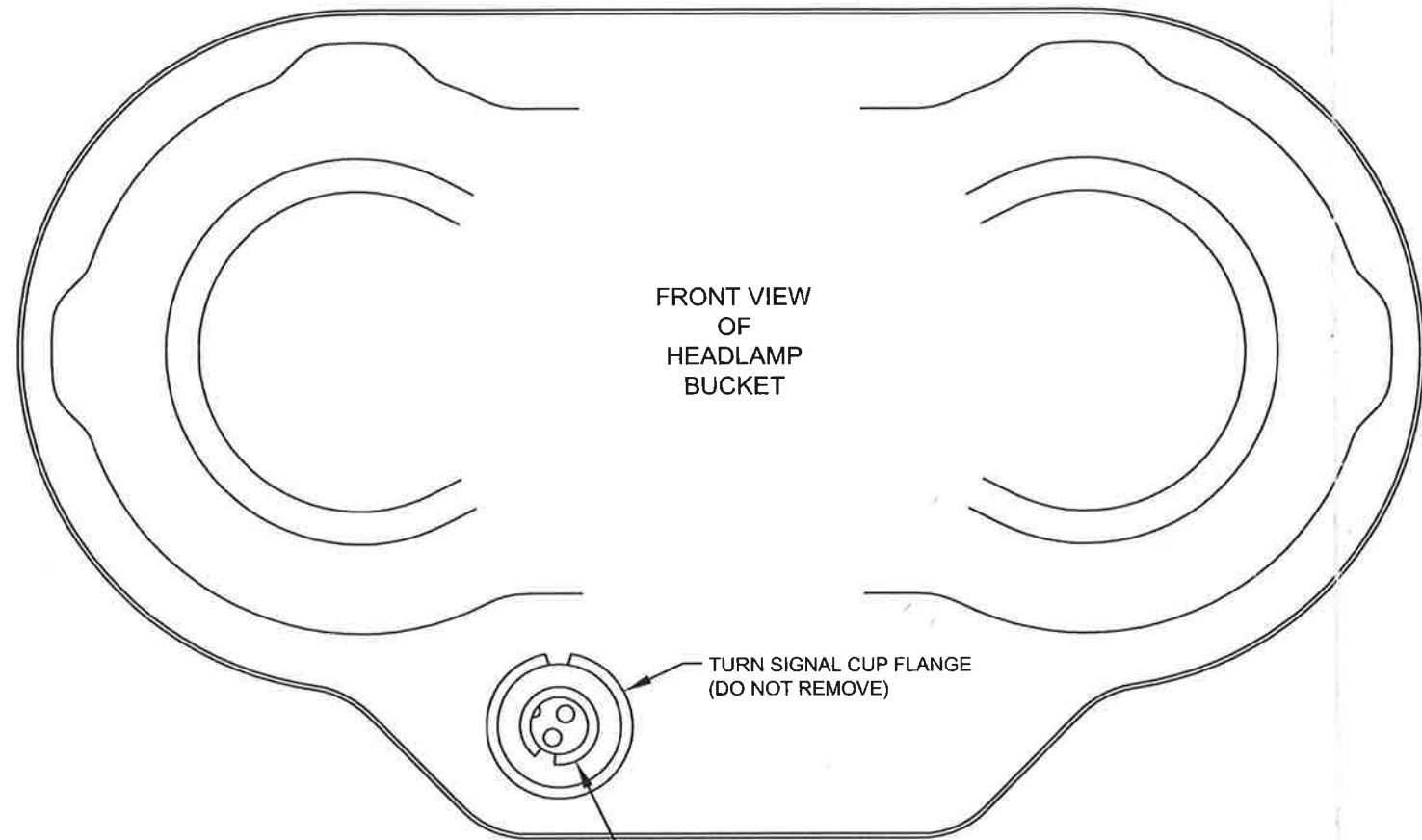

**STEP 1
REMOVE OLD LAMP SOCKET**

REAR SIDE OF TURN SIGNAL
CUP METAL SURFACE MUST BE
CLEANED TO ENSURE A GOOD
GROUND TO LAMP SOCKET

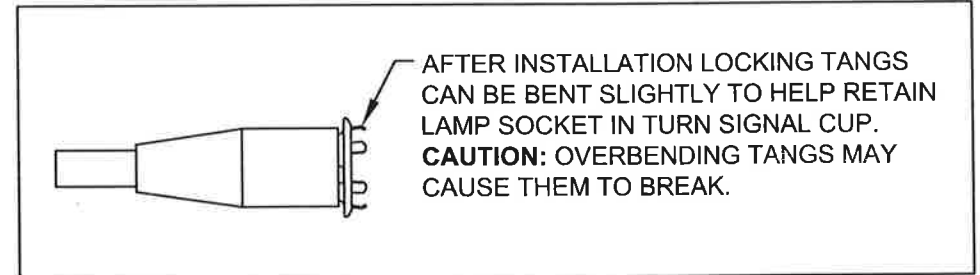
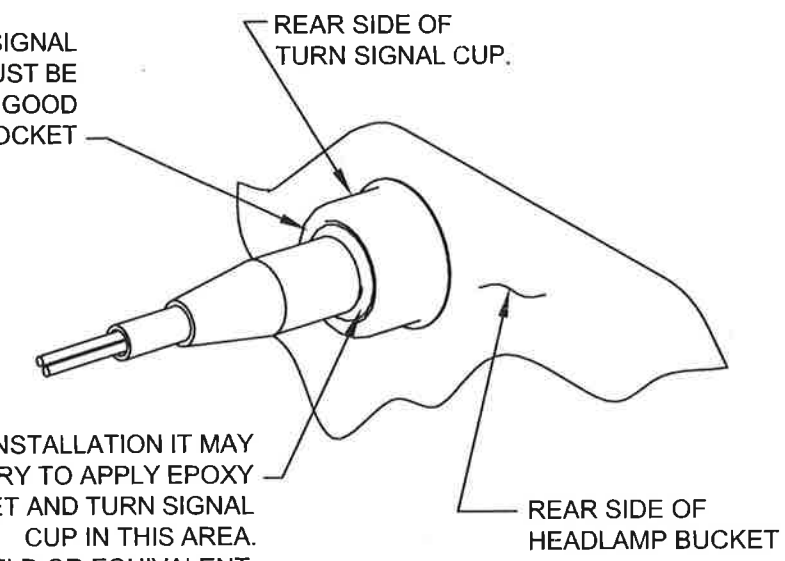

**STEP 2
INSTALL NEW LAMP SOCKET**

M&H ELECTRIC
FABRICATORS, INC.
AUTOMOTIVE LIGHTING SYSTEMS
(562) 926-9552 www.wiringhames.com

INSTRUCTION SHEET

92967988

D

C

B

A

8

7

6

5

4

3

2

1