

# Installation instructions for connector.

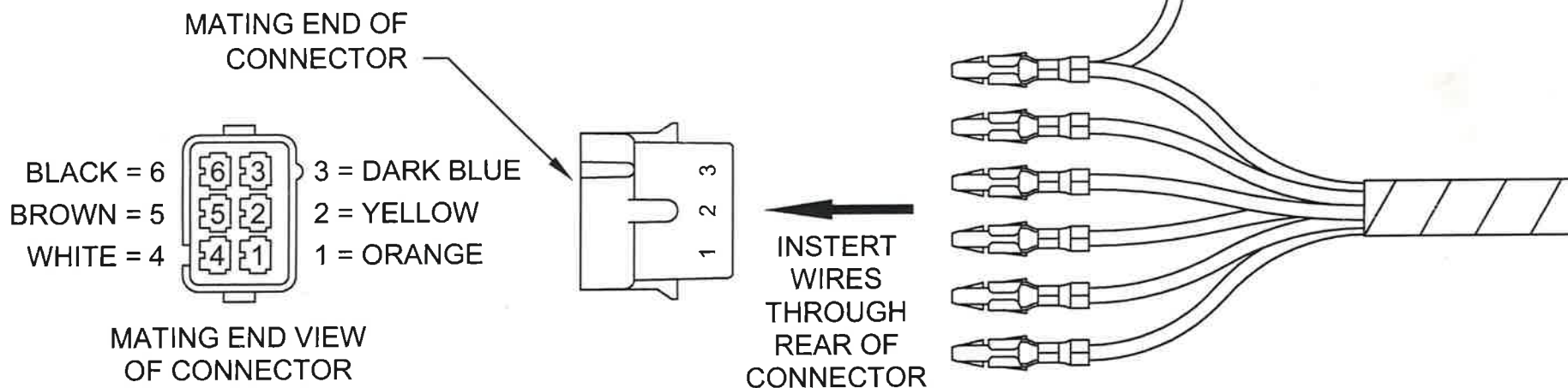

NOTE: HARNESS MUST BE INSTALLED PRIOR TO ASSEMBLING CONNECTOR TO HARNESS.

1. Remove old rear lamp harness.  
Note: It may be necessary to cut connector off old harness to remove from body of car.
2. Install rear lamp harness and route same as original.
3. Install each wire into respective cavities as shown.  
Insert each wire into cavity until it clicks in place.

**M&H** ELECTRIC  
FABRICATORS, INC.  
AUTOMOTIVE WIRING SYSTEMS  
(562) 926-9552 www.wiringharness.com

TITLE

INSTRUCTION SHEET

M&H NO.

PART NO.

92967874