

1. Plug the harness into the mating connector at the base of the steering column.
2. Connect the light blue, dark blue, yellow, pink, purple, and white wires at the opposite end of the harness to the factory under dash harness by matching the wire colors in the appropriate connectors of the under dash harness.
3. Connect the tan wire to the horn button lead.
4. Plug the red wire to a battery power source on the fuse panel. An auxiliary battery source at the back of the cigarette lighter may also be used by first removing the existing heavy red wire and plugging it into the red pigtail wire.
5. Install a heavy duty 2 prong flasher into the "V" shaped plastic connector to enable use of the 4-way flashers.
6. Install a 10 amp fuse into the in-line fuse holder.

M&H Electric Fabricators, Inc.
AUTOMOTIVE WIRING SYSTEMS
 Phone (562) 926-9552 Fax (562) 926-9572

TITLE
 INSTRUCTION SHEET
 STEERING COLUMN
 ADAPTER HARNESS

DWG NO.
92963628

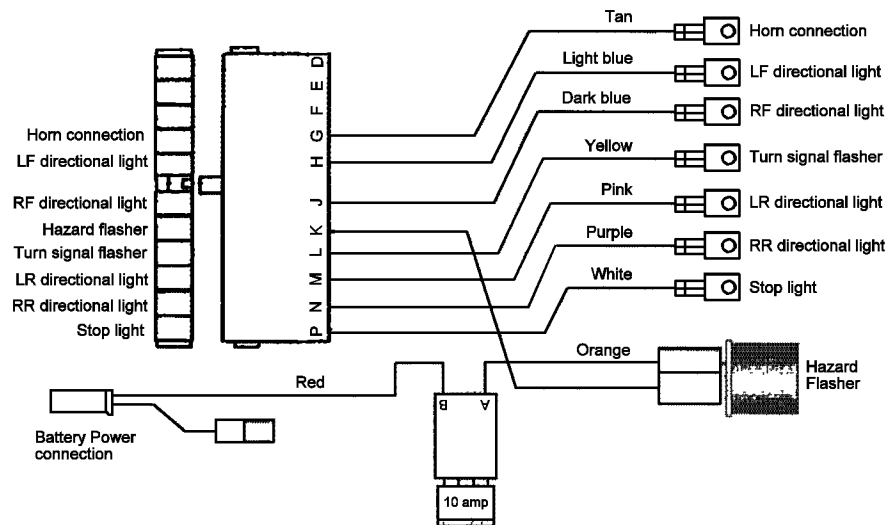

1. Plug the harness into the mating connector at the base of the steering column.
2. Connect the light blue, dark blue, yellow, pink, purple, and white wires at the opposite end of the harness to the factory under dash harness by matching the wire colors in the appropriate connectors of the under dash harness.
3. Connect the tan wire to the horn button lead.
4. Plug the red wire to a battery power source on the fuse panel. An auxiliary battery source at the back of the cigarette lighter may also be used by first removing the existing heavy red wire and plugging it into the red pigtail wire.
5. Install a heavy duty 2 prong flasher into the "V" shaped plastic connector to enable use of the 4-way flashers.
6. Install a 10 amp fuse into the in-line fuse holder.

M&H Electric Fabricators, Inc.
AUTOMOTIVE WIRING SYSTEMS
 Phone (562) 926-9552 Fax (562) 926-9572

TITLE
 INSTRUCTION SHEET
 STEERING COLUMN
 ADAPTER HARNESS

DWG NO.
92963628